

**COUNTY OF SAN MATEO  
PLANNING AND BUILDING DEPARTMENT**

**DATE:** June 21, 2018

**TO:** Zoning Hearing Officer

**FROM:** Planning Staff

**SUBJECT:** Consideration of a Use Permit Renewal, pursuant to Sections 6500 of the County Zoning Regulations, to allow the continued operation of a wireless telecommunication facility on an existing PG&E tower located at the end of Loma Vista Drive in the unincorporated Burlingame Hills area of San Mateo County.

County File Number: PLN 2001-00519

**PROPOSAL**

The applicant is proposing to renew their Use Permit for an existing Sprint wireless telecommunication facility located on an existing 98'-6" tall PG&E tower. The current facility consists of two (2) panel antennas (mounted at 49'-7" above grade) and a 180 sq. ft. equipment enclosure area located at the base of the tower screened by an existing 5-foot wooden fence. Though adjacent to I-280, this project site is not located within the Junipero Serra State Scenic Corridor.

The applicant is proposing maintenance items including the replacement of two existing panel antennas (to be located at 49'-9" above grade) and the installation of two new panel antennas (to be located at 50'-3" above grade) on the west side of the PG&E tower. In addition, Sprint is proposing to relocate two existing remote radio head (RRH) units from the equipment enclosure area and install four new RRH units near the proposed antennas. Sprint is also proposing to construct a new extension ladder and to install two new hybrid cables on the side of the existing PG&E tower. The proposed modifications qualify under the Federal Preemption as modifications that do not constitute a substantial change as defined in the Telecommunications Act.

**RECOMMENDATION**

That the Zoning Hearing Officer approve the Use Permit Renewal, County File Number PLN 2001-00519, by making the findings and adopting the conditions of approval listed in Attachment A of this staff report.

## **BACKGROUND**

Report Prepared By: Laura Richstone, Project Planner, 650/363-1829

Applicant: Frank Schabarum for Sprint

Owner: City and County of San Francisco and Pacific Gas & Electric (PG&E)

Location: At the end of Loma Vista Drive near the intersection of Trousdale and Highway 280, Burlingame

APN: 093-050-130

Size: 154.97 acres

Existing Zoning: Resource Management (RM)

General Plan Designation: Rural Open Space  
Sphere-of-Influence: City of Burlingame

Williamson Act: Not Contracted

Existing Land Use: Public Utility Easement

Water Supply: N/A

Sewage Disposal: N/A

Flood Zone: Zone X (area of minimal flooding): FEMA FIRM Panel 06081C0134E; effective October 16, 2012

Environmental Evaluation: Categorically except pursuant to Section 15301, Class 1 of the California Environmental Quality Act (CEQA) relating to the continued operation of an existing use.

Setting: The project parcel contains several PG&E towers supporting electric lines in a linear pattern along Highway 280 on San Francisco Watershed property. The project site is located roughly 100 feet east of Highway 280 and approximately 100 feet away from the nearest residential structure in a semi-forested area.

Chronology:

<u>Date</u>	<u>Action</u>
February 2, 1997	- Initial Use Permit Approved, USE96-0059
April 18, 2002	- Use Permit Renewal approved. New County File Number assigned, PLN 2001-00519.
July 19, 2007	- Use Permit Renewal approved
September 29, 2011	- Use Permit Renewal/Amendment submitted to remove and replace two panel antennas, and 2 equipment cabinets and add 2 new panel antennas and 6 RRH units. The project was never deemed complete and the Use Permit Renewal was never completed.
December 29, 2017	- Revised Use Permit Renewal and Amendment scope submitted to remove and replace two panel antennas, and add 2 new panel antennas, 4 RRH units, and 2 new hybrid cables. Proposed modifications qualify for Federal Preemption.
April 18, 2018	- Renewal application deemed complete.
June 21, 2018	- Zoning Hearing Officer public hearing.

**DISCUSSION**

A. KEY ISSUES

1. Compliance with Conditions of the Last Approval

The conditions from the last approval by the Zoning Hearing Officer on July 1, 2007 are assessed below on their compliance and if the conditions should be retained or revised.

Planning Department

- a. The equipment cabinets shall be surrounded by a five (5) foot wooden fence and the antennas shall be maintained a grey color.

Compliance with Condition? Yes.

Recommend to Retain Condition? Yes, but modified to reflect that the fence has been built and that the new equipment shall be painted a non-reflective gray color:

The applicant shall maintain the equipment enclosure fencing in good condition and perform repairs as necessary to serve its function as a screening device for the equipment cabinets. Any repairs and/or maintenance to the fence shall be of like colors and materials.

Prior to the issuance of a building permit, the applicant shall submit color samples for the antennas and equipment. The antennas and all associated equipment shall be painted gray to match the existing PG&E tower. Furthermore, all associated facility equipment shall be of non-reflective materials and/or colors. Paint colors shall be subject to review and approval by the Community Development Director. The applicant shall submit photos to the Current Planning Section for color verification after the applicant has painted the antennas and equipment the approved colors, but before a final building inspection is scheduled.

- b. This installation shall be removed in its entirety at that time when this technology becomes obsolete or this facility is no longer needed.

Compliance with Condition? Yes.

Recommend to Retain Condition? Yes but modified to reflect the following:

When this technology becomes obsolete or the facility is no longer needed, the applicant shall remove this facility and all equipment in its entirety. The owner and/or operator of the facility shall notify the Planning Department upon abandonment of the facility.

- c. The applicant shall not enter into a contract with the landowner or lessee which reserves for one company exclusive use of the tower structure for telecommunications facilities.

Compliance with Condition? Yes.

Recommend to Retain Condition? Yes.

- d. This permit shall be valid for ten (10) years from the date of final approval, with an option for renewal at the discretion of the applicant. Renewal of this permit shall be applied for six months prior to expiration and shall be accompanied by the renewal application and fees applicable at that time of renewal.

Compliance with Condition? Partial. This Use Permit expired July 2011. The applicant submitted an application for renewal on September 26, 2011, however the project was never deemed complete and the Use Permit Renewal Process was never completed.

Recommend to Retain Condition? Yes but modified to reflect the new Use Permit terms and dates as follows:

This Use Permit shall be valid for ten (10) years following the date of final approval, valid through June 21, 2028. The applicant shall file for a renewal of this permit six months (December 7, 2027) prior to expiration with the County Planning and Building Department if continuation of the use is desired.

#### Building Department

- e. The expired building permit (BLD 2002-00933) shall be reinstated and finalized within sixty (60) days of Use Permit renewal.

Recommend to Retain Condition? *No. The condition is no longer applicable. This outstanding building permit is for another cell site on the same parcel (Metro PCS County File No. PLN2001-00395) and was applied to this permit in error.*

#### Additional Recommended Conditions

Staff recommends the following additional standard conditions of approval:

- f. This approval applies only to the proposal described in the report and materials approved by the Zoning Hearing Officer on June 21, 2018. Minor modifications to the project may be approved by the Community Development Director if they are consistent with the intent of, and in substantial conformance with this approval.
- g. Any change in use or intensity shall require an amendment to this use permit. Use permit amendments require an application for amendment, payment of applicable fees, and consideration at a public hearing.
- h. The applicant shall maintain all necessary licenses and registrations from the Federal Communications Commission (FCC) and any other applicable regulatory bodies for the operation of the subject facility at this site. The applicant shall supply the Planning Department with evidence of such licenses and registrations. If any required license is ever revoked, the applicant shall inform the Planning Department of

the revocation within ten (10) days of receiving notice of such revocation.

- i. This facility and all equipment associated with it shall be removed in its entirety by the applicant within ninety (90) days if the FCC license and registration are revoked or if the facility is abandoned or no longer needed and subject to a building permit as required by the Building Department. The owner and/or operator of the facility shall notify the Planning Department upon abandonment of the facility.
- j. There shall be no external lighting associated with this use. Wireless telecommunication facilities shall not be lighted or marked unless required by the FCC or Federal Aviation Administration (FAA).
- k. A building permit shall be issued prior to the start of any construction work associated with this amendment approval.
- l. Appropriate warning signs shall be posted at the base of the tower regarding the potential risks of radio frequency exposure. The applicant shall submit photos to the Current Planning Section for verification after the required signage has been posted, but before a final building inspection is scheduled.
- m. This permit does not allow for the removal of any trees. Removal of any tree with a diameter of 12 inches or greater, as measured 4.5 feet above the ground, shall require additional review by the Planning Department prior to removal.

## 2. Conformance with the General Plan

Staff has determined that the project complies with all applicable General Plan Policies including the following:

### Visual Qualities Policies

Policies 4.15 (*Appearance of New Development*) and 4.21 (*Utility Structures*) seek to promote and enhance good design, site relationships and other aesthetic considerations including the appearance of utility structures in an effort of minimize adverse visual impacts.

The proposed antenna modifications, which include replacing two antennas, adding two new antennas, installing six Remote Radio Head (RRH) units on brackets behind the proposed antennas, constructing a new extension ladder, and running two new hybrid cables up the side of the existing PG&E tower are not expected to create a significant visual impact to the area given the scale of the added equipment to the PG&E tower, distance from public

viewpoints along I-280, equipment mounting height from the ground level, and partial screening from mature trees along the northbound approach of I-280. The replaced antennas will be mounted 50'-3" above grade and will be located at approximately the same vertical height of the existing antennas which are currently mounted at 49'-7" above grade. Staff has added a condition of approval to ensure the antennas and tower-mounted equipment are painted a non-reflective gray color to blend in with the PG&E tower and to minimize visual impacts.

Sprint's existing ground equipment area is located under the PG&E tower, is surrounded by a 5-foot tall wooden fence for screening purposes, and is not visible from I-280 due to existing mature trees and vegetation along the eastern side of I-280. No visual impacts from the continued operation of the wireless facility are expected.

### General Land Use

Policies 9.42 (*Development Standards for Land Use Compatibility in General Open Space Lands*) 9.43 (*San Francisco Watershed Lands*) recognize San Francisco Watershed lands as unique areas and seek to retain their open space value by locating development in areas that cause the least disturbance to visual, wildlife, and recreational resources. The proposed equipment is the same size and will be mounted at approximately the same height of the existing antennas and will not detract from the visual character of the parcel. The facility is accessed by an existing road off of Skyview Drive and no new roads are proposed. By mounting the proposed antennas on an existing PG&E tower, the need to introduce new towers or poles that would negatively impact the visual and scenic quality of the area is eliminated.

### 3. Conformance with the Zoning Regulations

#### a. RM (Resource Management) District Regulations

The project site is located within the Resource Management District. Wireless telecommunication facilities are an allowed use in this district subject to the issuance of a use permit. The initial use permit for this site was granted in 1997.

The applicant proposes to install a new access ladder and antennas among other modifications, on the existing PG&E transmission tower. These modifications qualify under the Federal Preemption as maintenance modifications because they do not constitute a substantial change. Modifications that add no more than 4 new cabinets, do not increase the height of the tower, require no excavation/development outside the current site, and do not eliminate

concealment elements of the eligible support structure are considered minor maintenance modifications under the Telecommunications Act and do not require County approval (i.e. Federally Preemption).

b. Development Review Criteria

The project complies with the applicable Site Design Criteria and Utilities Criteria, as set forth in Sections 6324.2 and 6324.3 respectively. These criteria seek to ensure that development is situated and designed so that its presence is subordinate to the existing natural characteristics of the site, avoids substantially detracting from the scenic and visual quality of the County, and employ colors and materials that blend with the surrounding natural environment.

4. Conformance with the Wireless Telecommunication Facilities Ordinance

According to Section 6512.6 of the Wireless Telecommunication Facilities Ordinance, existing facilities built prior to January 9, 2009 are subject to the provisions of the Ordinance related to new facilities. Staff has reviewed the project against the provisions of the Wireless Telecommunication Facilities Ordinance and determined that the project complies with the applicable standards discussed below.

a. Development and Design Standards

**Section 6512.2 A prohibits location in a Sensitive Habitat as defined by Policy 1.8 of the General Plan for facilities proposed outside the Coastal Zone.**

The site of the existing and proposed Sprint facility is not near mapped sensitive habitats.

**Section 6512.2.B prohibits wireless facilities to be located in residential-zoned areas, unless the applicant demonstrates that no other site allows feasible or adequate capacity and coverage. Evidence shall include an alternative site analysis within 2.5 miles of the proposed facility.**

The existing wireless telecommunication site is located on an existing PG&E tower in the RM Zoning District along I-280 and not in a residentially zoned district.



**Section 6512.2.C prohibits wireless telecommunication facilities to be located in areas where co-location on existing facilities would provide equivalent coverage with less environmental impact.**

This facility was established under a 1997 use permit approval and has been in operation ever since. Sprint is proposing to upgrade this existing facility and is not proposing to relocate. If a different location were proposed, there would be the potential for new environmental impacts depending on the location of the new site and construction of a new facility elsewhere. Maintaining and upgrading the current facility minimizes potential environmental impacts while continuing to provide consistent coverage. Conditions of approval Nos. 6 and 8 which require the facility to maintain all applicable FCC licenses and/or remove the facility in its entirety within 90 days if any such licenses are revoked have been added to the recommended conditions of approval to ensure that this facility will have as little environmental impact as possible. The addition of condition of approval No. 3 also ensures that environmental impacts from this site are minimized by requiring any change of use or intensity of this facility to obtain a use permit amendment and undergo staff review.

The radio frequency (RF) report prepared by SiteSafe Inc. included an analysis of Sprint's proposed modifications (Attachment E). The measured cumulative public exposure level of any person at ground level is less than 1% of the most restrictive public limit. Higher emission levels (exceeding 100% of the general public MPE) are expected at 47' above grade. While these emission levels exceed general public MPE levels, they fall within acceptable occupational MPE limits and are safe for trained professionals to be in. The general public will not be exposed to these higher MPE levels as no tall structures surround the facility and as public access to the site is restricted. As detailed in the RF report, the existing wireless facility must place RF exposure signs on the PG&E tower to inform everyone who has access to the site that there may be RF levels in excess of the FCC general public MPE levels. Staff has added recommended condition of approval No. 11 to require the installation of these signs before a final building inspection for the proposed facility is scheduled.

**Section 6512.2.D requires wireless telecommunication facilities to be constructed so as to accommodate and be made available for co-location unless technologically infeasible.**

Though Sprint is currently the only cellular provider mounted on this PG&E tower, the placement of the existing facility and proposed

modifications do not preclude other wireless facilities from co-locating on this structure.

**Sections 6512.2.E-G seek to minimize and mitigate visual impacts from public views by ensuring that appropriate vegetative screening, painting of equipment, or other methods of blending equipment in with the surrounding environment are implemented and requiring facilities to be constructed of non-reflective materials.**

The subject wireless facility is located outside the Junipero Serra State Scenic Corridor on a PG&E tower adjacent to, and partially visible from, I-280. Though the proposed new antennas will be mounted at approximately the same height as the existing antennas, to minimize visual impacts, the applicant will be required to paint the antenna panels, associated equipment, and hybrid cables a non-reflective gray color to match the existing PG&E tower. Additionally, proposed conditions of approval Nos. 9 and 12 which prohibit exterior lighting and the removal of any significant or heritage tree seek to mitigate any potential visual impacts this facility may pose to public views. Staff believe that the visual impacts from the facility's proposed modifications will not be overly dominant when viewed in context of the existing 98' tall PG&E tower and due to the fact that the facility is partially screened by existing vegetation on the northbound I-280 approach.

**Section 6512.2.H requires compliance with the underlying zoning district.**

The project site is located within the Resource Management (RM) Zoning District. Refer to Section A.3 above (Zoning Regulations) for further discussion.

**Section 6512.2.I(1) requires that no structure or appurtenance shall exceed the height of the forest canopy by more than 10% or five feet, whichever is less in forested areas of the Resource Management District.**

The existing PG&E tower sits on a partially wooded parcel east of I-280. Though only partially screened by trees, the proposed antenna height of 50'-3" above grade will not place the antennas above the canopies of the surrounding trees (see Attachment D for pictures).

**Section 6512.2.K requires the overall footprint of a facility to be as minimal as possible and not cover more than 15% in area of the lot or an area greater than 1,600 square feet in residential districts.**

While the wireless facility is mounted to an existing PG&E tower, a ground level equipment enclosure area is located at the base of the tower. And while the facility is not located in a residential district, the existing 180 sq. ft. equipment enclosure area sits within the footprint of the PG&E tower, does not cover more than 15% of the lot, and does not contribute to the overall footprint of the tower. No expansion of the equipment area or the foot print of the PG&E tower is proposed.

**Section 6512.2.L prohibits diesel generators as emergency power sources unless electricity, natural gas, solar, wind or other renewable energy sources are not feasible.**

No diesel generator is proposed.

b. Performance Standards

The project, as proposed and conditioned, meets the required performance standards of Section 6512.3 for lighting, licensing, provision of a permanent power source, timely removal of the facilities, and visual resource protection. There is no lighting proposed on the PG&E tower, proper licenses will be obtained from both the FCC and CPUC, power for the facilities will be provided by PG&E, visual impacts will be reduced to a less than significant level through design and proper mitigations, and conditions of approval 6 and 8 require maintenance and/or removal of the facilities when necessary or no longer in use.

5. Compliance with the Use Permit Findings

Under the provisions of Section 6500, wireless telecommunication facilities are permitted in the RM Zoning District subject to the issuance of a use permit. In order to approve the subject use permit renewal, the following findings must be made:

- a. **That the establishment, maintenance and/or conducting of the use will not, under the circumstances or this particular case, be detrimental to the public welfare or injurious to property or improvements in said neighborhood.**

Wireless telecommunication facilities, including the proposed maintenance modifications, require the submittal of a radio frequency report (RF) and compliance with applicable FCC public exposure limits. As previously discussed, the submitted report identified emission levels exceeding 100% of the General Public MPE for the areas in front of the panel antennas (at 47' above grade). Although these levels exceed the maximum public exposure limit, the public is restricted from accessing this location. The occupational MPE for this site is within the acceptable range for trained professionals. The RF report concluded that the site will comply with all applicable FCC Rules and Regulations upon installation of caution signs at the base of the transmission tower. Condition of approval No. 11 has been added to ensure that warning signs regarding potential RF exposure shall be posted on the tower. Given the RF report, and recommended condition of approval No. 11, staff has determined that the proposed project will not be detrimental to the public welfare or injurious to property or improvements within the area.

**b. That the proposed project is necessary for the public health, safety, convenience or welfare of the community.**

Staff has determined that the continued operation of the existing facility and modifications will allow for increased clarity, range, and capacity of the existing wireless network and will therefore enhance services and benefit both public and private users. The continued operation of the communication facility is considered necessary for public health, safety, convenience and welfare.

**B. ENVIRONMENTAL REVIEW**

This project is categorically exempt from environmental review pursuant to Section 15301, Class 1, of the California Environmental Quality Act (CEQA) relating to the continued operation of an existing use.

**C. REVIEWING AGENCIES**

Building Inspection Section  
Department of Public Works  
San Mateo County Fire Department  
Burlingame Hills Improvement Association

**ATTACHMENTS**

- A. Recommended Findings and Conditions of Approval
- B. Vicinity Map
- C. Project Plans

- D. Photo Simulations and Photos
- E. Radio Frequency Report, prepared by Safe Site Inc., dated November 13, 2017

LAR:aow – LARCC0211\_WAU.DOCX

County of San Mateo  
Planning and Building Department

**RECOMMENDED FINDINGS AND CONDITIONS OF APPROVAL**

Permit or Project File Number: PLN 2001-00519

Hearing Date: June 21, 2018

Prepared By: Laura Richstone  
Project Planner

For Adoption By: Zoning Hearing Officer

**RECOMMENDED FINDINGS**

Regarding the Environmental Review, Find:

1. That the project is categorically exempt from environmental review, per Class 1, Section 15301, of the California Environmental Quality Act (CEQA) Guidelines for continued operation of existing facilities.

Regarding the Use Permit, Find:

2. That the establishment, maintenance and/or conducting of the use will not, under the circumstances of the particular case, be detrimental to the public welfare or injurious to property or improvements in said neighborhood, since the proposed improvements will comply with all applicable Federal Communications Commission (FCC) Rules and Regulations regarding public and occupational radio frequency exposure limits. Furthermore, the site will continue to require only minimal routine service visits of the otherwise non-staffed facility, no additional traffic will be generated, and the amendment will not intensify the use of the property.
3. That the project is necessary for the public health, safety, convenience or welfare by enhancing and increasing the capacity and network coverage to the surrounding area to accommodate the growing demand from private citizens and public agencies, including emergency services. Furthermore, there is no evidence to suggest that the operation or proposed modification to this facility has or would cause a detriment to the public health or safety. The benefits provided by the added cellular coverage will outweigh any impacts caused by placing the antennas 8" higher than the current antennas. The placement of the proposed modifications will not increase the height of the existing PG&E tower and will be screened by the surrounding tree canopy.

## **RECOMMENDED CONDITIONS OF APPROVAL**

### **Current Planning Section**

1. This approval applies only to the proposal described in the report and materials approved by the Zoning Hearing Officer on June 21, 2018. Minor modifications to the project may be approved by the Community Development Director if they are consistent with the intent of, and in substantial conformance with this approval.
2. This Use Permit shall be valid for ten (10) years following the date of final approval, valid through June 21, 2028. The applicant shall file for a renewal of this permit six months (December 7, 2027) prior to expiration with the County Planning and Building Department if continuation of the use is desired.
3. Any change in use or intensity shall require an amendment to this use permit. Use permit amendments require an application for amendment, payment of applicable fees, and consideration at a public hearing.
4. The applicant shall maintain the equipment enclosure fencing in good condition and perform repairs as necessary to serve its function as a screening devise for the equipment cabinets. Any repairs and/or maintenance to the fence shall be of like colors and materials.
5. Prior to the issuance of a building permit, the applicant shall submit color samples for the antennas and equipment. The antennas and all associated equipment shall be painted gray to match the existing PG&E tower. Furthermore, all associated facility equipment shall be of non-reflective materials and/or colors. Paint colors shall be subject to the review and approval by the Community Development Director. The applicant shall submit photos to the Current Planning Section for color verification after the applicant has painted the antennas and equipment the approved colors, but before a final building inspection is scheduled.
6. The applicant shall maintain all necessary licenses and registrations from the Federal Communications Commission (FCC) and any other applicable regulatory bodies for the operation of the subject facility at this site. The applicant shall supply the Planning Department with evidence of such licenses and registrations. If any required license is ever revoked, the applicant shall inform the Planning Department of the revocation within ten (10) days of receiving notice of such revocation.
7. The applicant shall not enter into a contract with the landowner or lessee which reserves for one company exclusive use of the tower structure for telecommunications facilities.

8. This facility and all equipment associated with it shall be removed in its entirety by the applicant within ninety (90) days if the FCC license and registration are revoked or if the facility is abandoned or no longer needed and subject to a building permit as required by the Building Department. The owner and/or operator of the facility shall notify the Planning Department upon abandonment of the facility.
9. There shall be no external lighting associated with this use. Wireless telecommunication facilities shall not be lighted or marked unless required by the FCC or Federal Aviation Administration (FAA).
10. A building permit shall be issued prior to the start of any construction work associated with this amendment approval.
11. Appropriate warning signs shall be posted at the base of the tower regarding the potential risks of radio frequency exposure. The applicant shall submit photos to the Current Planning Section for verification after the required signage has been posted, but before a final building inspection is scheduled.
12. This permit does not allow for the removal of any trees. Removal of any tree with diameter of 12 inches or greater, as measured 4.5 feet above the ground, shall require additional review by the Planning Department prior to removal.
13. When this technology becomes obsolete or the facility is no longer needed, the applicant shall remove this facility and all equipment in its entirety. The owner and/or operator of the facility shall notify the Planning Department upon abandonment of the facility.

LAR:aow – LARCC0211\_WAU.DOCX





Vicinity Map

***San Mateo County Zoning Hearing Officer Meeting***

Owner/Applicant: \_\_\_\_\_

Attachment: \_\_\_\_\_

File Numbers: \_\_\_\_\_

SECTOR	ANTENNA	AZMUTH	RAD CENTER	NUMBER OF ANTENNAS	ANTENNA MODEL	ELECTRICAL TILT	MECHANICAL TILT	RRH	CABLE TYPE	HYBRID LENGTH (±5')
1	800MHz-1900MHz	0°	47'-3"	1	RR90-17-00P	0	0	1	(2) 1-1/4"Ø COAXIAL CABLE	116'
2	800MHz-1900MHz	120°	47'-3"	1	RR90-17-00P	0	0	1	(2) 1-1/4"Ø COAXIAL CABLE	95'

(E) ANTENNA SCHEDULE

4

SECTOR	ANTENNA	AZMUTH	RAD CENTER	NUMBER OF ANTENNAS	ANTENNA MODEL	ELECTRICAL TILT	MECHANICAL TILT	RRH	CABLE TYPE	HYBRID LENGTH (±5')
1	806MHz-1995MHz	0°	47'-3"	1	KMW ET-1-TS-70-15-62-18-R-RD	0	0	2	(N) HYBRID CABLE	116'
1	817MHz-962MHz-2450MHz-2650MHz	0°	47'-3"	1	COMMSCOPE DT4659-2XR	0	0	1	(N) HYBRID CABLE	116'
2	806MHz-1995MHz	120°	47'-3"	1	KMW ET-1-TS-70-15-62-18-R-RD	0	0	2	(N) HYBRID CABLE	95'
2	817MHz-962MHz-2450MHz-2650MHz	120°	47'-3"	1	COMMSCOPE DT4659-2XR	0	0	1	(N) HYBRID CABLE	95'

(N) ANTENNA SCHEDULE

3



OVERALL SITE PLAN 11x17 SCALE: 1"=1,000'  
24x36 SCALE: 1"=500'

2

SITE PLAN 11x17 SCALE: 1"=80'  
24x36 SCALE: 1"=40'

1

**Sprint**  
6580 SPRINT PARKWAY  
OVERLAND PARK, KANSAS 66251

**jra**  
Jeffrey Rome | ASSOCIATES  
architecture | telecommunications  
131 Innovation Drive, Suite 100  
Livermore, California 94551  
tel 949.760.3929 | fax 949.760.3933

STAMP  
REGISTERED ARCHITECT  
JEFFREY ROME  
CASCADIA  
EXP. 2/28/17  
STATE OF CALIFORNIA

PROPRIETARY INFORMATION  
THE INFORMATION CONTAINED IN THIS SET OF CONSTRUCTION DOCUMENTS IS PROPRIETARY BY NATURE. ANY USE OR DISCLOSURE OTHER THAN THAT WHICH RELATES TO SPRINT IS STRICTLY PROHIBITED.

DESCRIPTION	DATE	BY	REV
PG&E REDLINES 2	07/10/17	ZH	2
GPS ANTENNA	08/10/17	RN	3
CM COMMENTS	09/15/17	BV	4
PG&E COMMENTS	09/29/17	BV	5
PG&E COMMENTS 2	10/06/17	ZH	6
4-PORT 800 RRU	11/17/17	RN	7

NOT FOR CONSTRUCTION UNLESS LABELED AS CONSTRUCTION SET

PROJECT NAME  
**DO MACRO UPGRADE**

SITE NAME  
**JEFFERSON & SNEATH/MARTIN**

SITE CASCADE  
**FS04XC063**

323 SKYLINE BOULEVARD  
BURLINGAME, CALIFORNIA 94010

SHEET TITLE  
**SITE PLAN AND ANTENNA SCHEDULE**

**A-1**

JRA JOB NUMBER: 161628

# San Mateo County Zoning Hearing Officer Meeting

Owner/Applicant:

Attachment:

File Numbers:



6580 SPRINT PARKWAY  
OVERLAND PARK, KANSAS 66251



Jeffrey Rome | ASSOCIATES

architecture | telecommunications  
131 Innovation Drive, Suite 100  
Troy, MI, Call for info: 924.617  
tel 949.760.3929 | fax 949.760.3931

STAMP



PROPRIETARY INFORMATION

THE INFORMATION CONTAINED IN THIS SET OF CONSTRUCTION DOCUMENTS IS PROPRIETARY BY NATURE. ANY USE OR DISCLOSURE OTHER THAN THAT WHICH RELATES TO SPRINT IS STRICTLY PROHIBITED.

REVISIONS

DESCRIPTION	DATE	BY	REV
PO&E REDLINES 2	07/10/17	ZN	2
GPS ANTENNA	08/10/17	RN	3
CM COMMENTS	09/15/17	BV	4
PO&E COMMENTS	09/29/17	BV	5
PO&E COMMENTS 2	10/06/17	ZN	6
4-PORT 800 RRU	11/17/17	RN	7

NOT FOR CONSTRUCTION UNLESS LABELED AS CONSTRUCTION SET

PROJECT NAME

DO MACRO UPGRADE

SITE NAME

JEFFERSON & SNEATH/MARTIN

SITE CASCADE

FS04XC063

323 SKYLINE BOULEVARD  
BURLINGAME, CALIFORNIA 94010

SHEET TITLE

ENLARGED SITE PLAN

A-2

DATE PLOTTED: 11/17/17

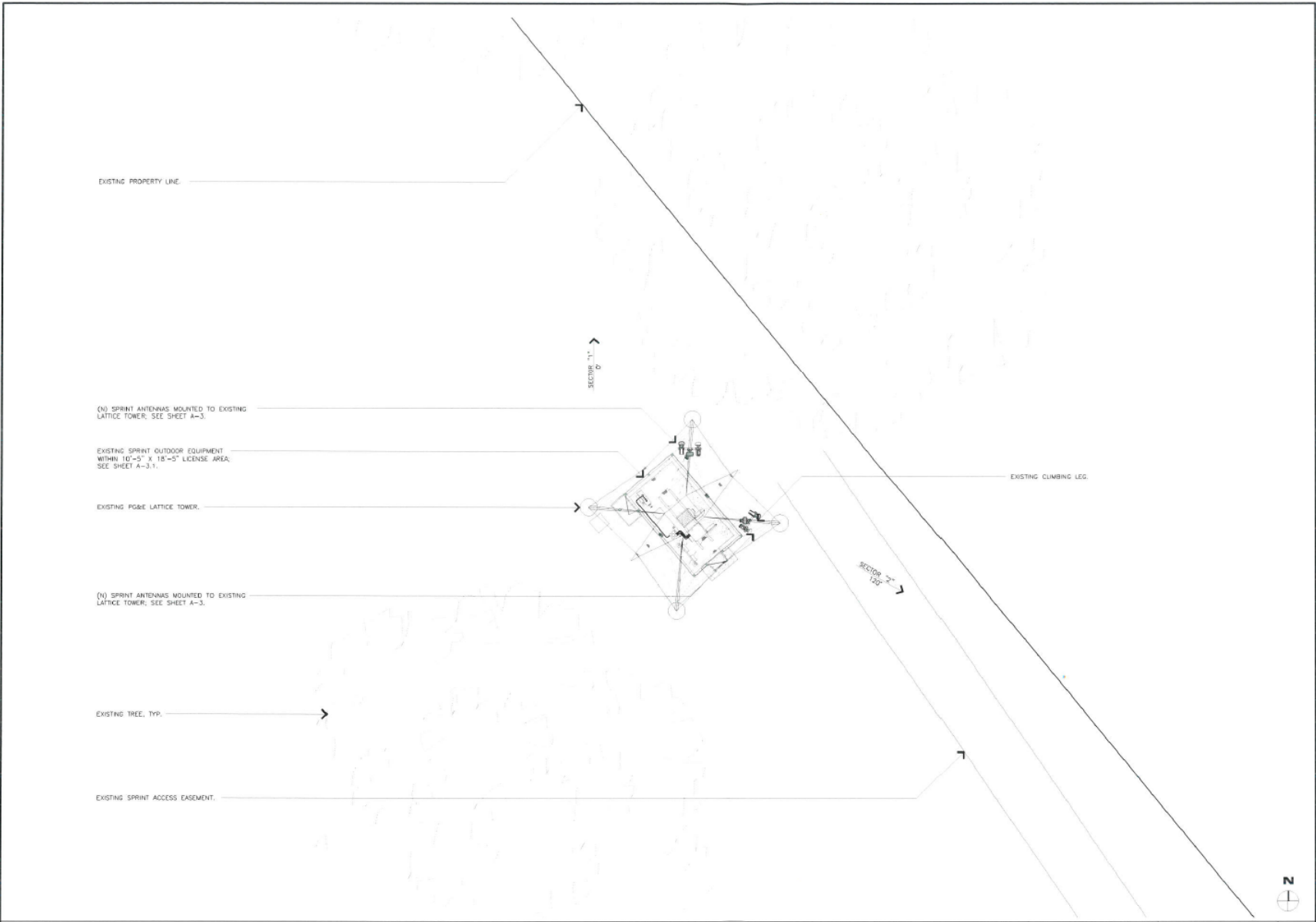

ENLARGED SITE PLAN

11x17 SCALE: 1/16"=1'-0"  
 24x36 SCALE: 1/8"=1'-0"  
 0 4' 8' 16' 1

# San Mateo County Zoning Hearing Officer Meeting

Owner/Applicant: \_\_\_\_\_ Attachment: \_\_\_\_\_

File Numbers: \_\_\_\_\_



STAMP



**PROPRIETARY INFORMATION**  
 THE INFORMATION CONTAINED IN THIS SET OF CONSTRUCTION DOCUMENTS IS PROPRIETARY BY NATURE. ANY USE OR DISCLOSURE OTHER THAN THAT WHICH RELATES TO SPRINT IS STRICTLY PROHIBITED.

DESCRIPTION	REVISIONS	DATE	BY	REV
PG&E REDLINES	2	07/10/17	ZN	2
GPS ANTENNA		08/10/17	RN	3
CM COMMENTS		09/15/17	BV	4
PG&E COMMENTS		09/29/17	BV	5
PG&E COMMENTS		2/10/08/17	ZN	6
4-PORT 800 RRU		11/17/17	RN	7

NOT FOR CONSTRUCTION UNLESS LABELED AS CONSTRUCTION SET

PROJECT NAME  
**DO MACRO UPGRADE**  
 SITE NAME  
**JEFFERSON & SNEATH/MARTIN**  
 SITE CASCADE  
**FS04XC063**  
 323 SKYLINE BOULEVARD  
 BURLINGAME, CALIFORNIA 94010

SHEET TITLE

ANTENNA LAYOUT

**A-3**

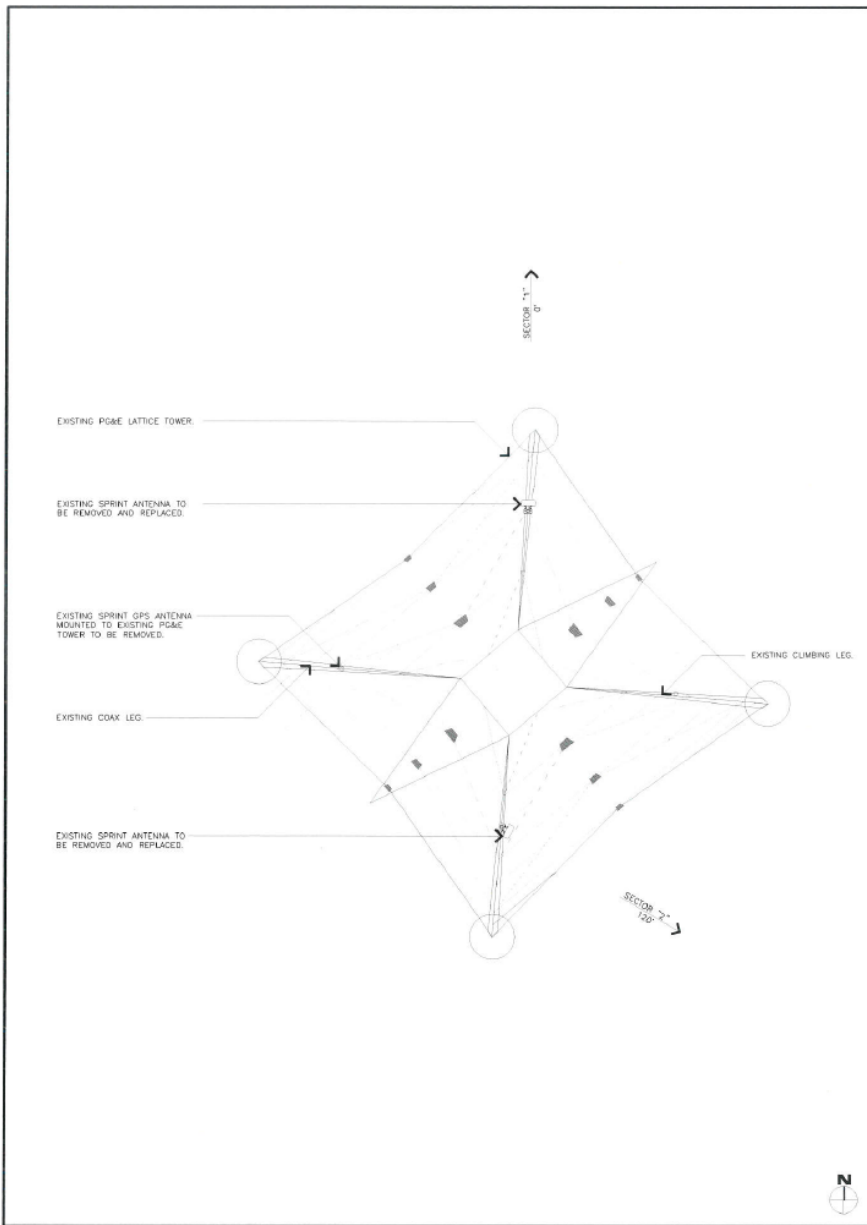

**EXISTING ANTENNA PLAN**  
 11x17 SCALE: 1/8"=1'-0"  
 22x34 SCALE: 1/4"=1'-0"  
 0 2' 4' 8'

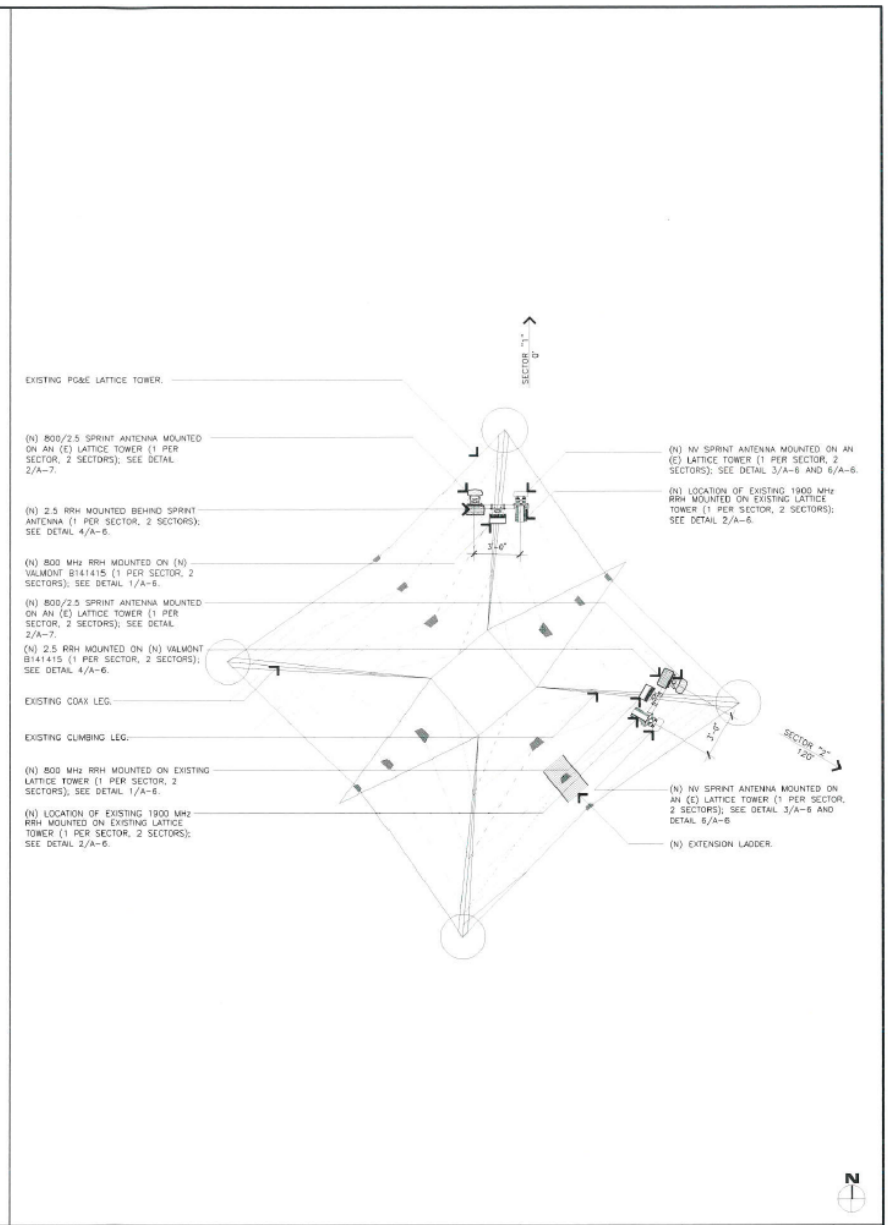

**(N) ANTENNA PLAN**  
 11x17 SCALE: 1/8"=1'-0"  
 22x34 SCALE: 1/4"=1'-0"  
 0 2' 4' 8'

**San Mateo County Zoning Hearing Officer Meeting**

Owner/Applicant: \_\_\_\_\_ Attachment: \_\_\_\_\_  
 File Numbers: \_\_\_\_\_



6580 SPRINT PARKWAY  
OVERLAND PARK, KANSAS 66251



**Jeffrey Rome** ASSOCIATES

architecture | telecommunications

131 Innovation Drive, Suite 300  
Irvine, California 92617  
tel 949.760.3929 | fax 949.760.3931

STAMP



**PROPRIETARY INFORMATION**

THE INFORMATION CONTAINED IN THIS SET OF CONSTRUCTION DOCUMENTS IS PROPRIETARY BY NATURE. ANY USE OR DISCLOSURE OTHER THAN THAT WHICH RELATES TO SPRINT IS STRICTLY PROHIBITED.

REVISIONS				
DESCRIPTION	DATE	BY	REV	
PG&E REDLINES 2	07/10/17	ZN	2	
GPS ANTENNA	06/10/17	RN	3	
CM COMMENTS	06/15/17	BV	4	
PG&E COMMENTS	09/29/17	BV	5	
PG&E COMMENTS 2	10/06/17	ZN	6	
4-PORT 800 IRU	11/17/17	RN	7	

NOT FOR CONSTRUCTION UNLESS LABELED AS CONSTRUCTION SET

PROJECT NAME

**DO MACRO UPGRADE**

SITE NAME

**JEFFERSON & SNEATH/MARTIN**

SITE CASCADE

**FS04XC063**

323 SKYLINE BOULEVARD  
BURLINGAME, CALIFORNIA 94010

SHEET TITLE

**EQUIPMENT LAYOUT**

**A-3.1**

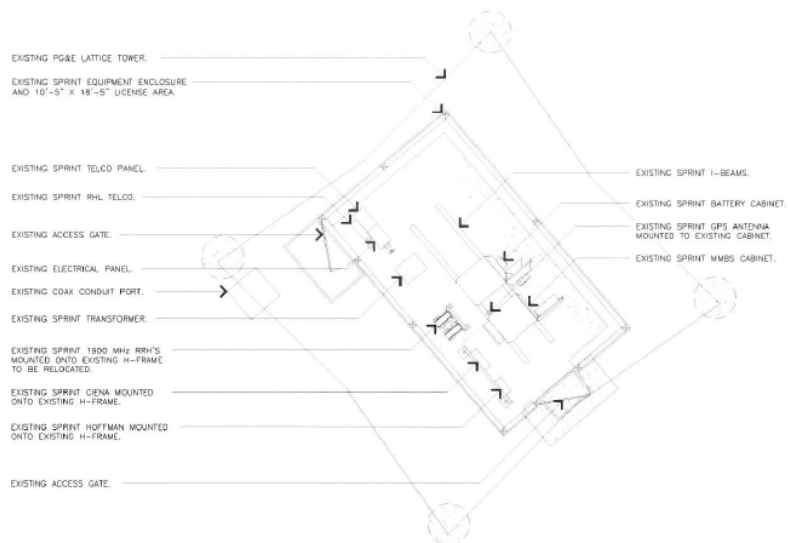

EXISTING EQUIPMENT PLAN

11x17 SCALE: 1/8"=1'-0"  
24x36 SCALE: 1/4"=1'-0"



**2**

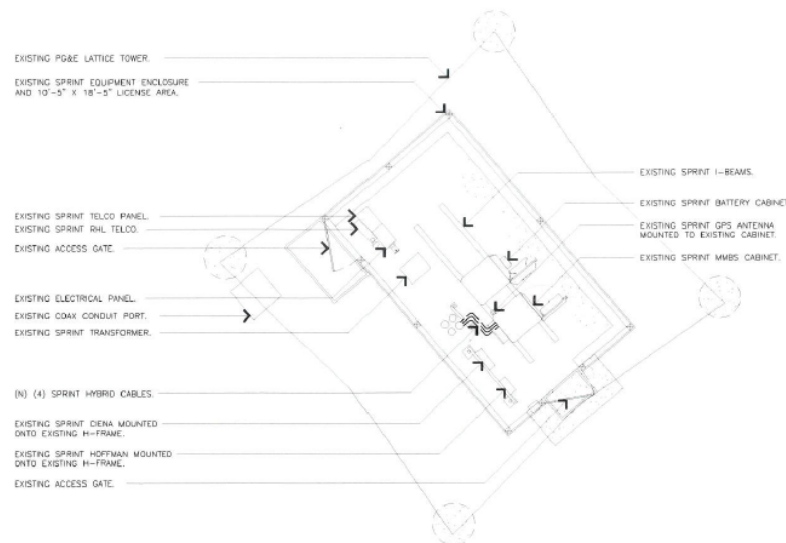

(N) EQUIPMENT PLAN

11x17 SCALE: 1/8"=1'-0"  
24x36 SCALE: 1/4"=1'-0"



**1**

# San Mateo County Zoning Hearing Officer Meeting

Owner/Applicant: \_\_\_\_\_

File Numbers: \_\_\_\_\_

Attachment: \_\_\_\_\_

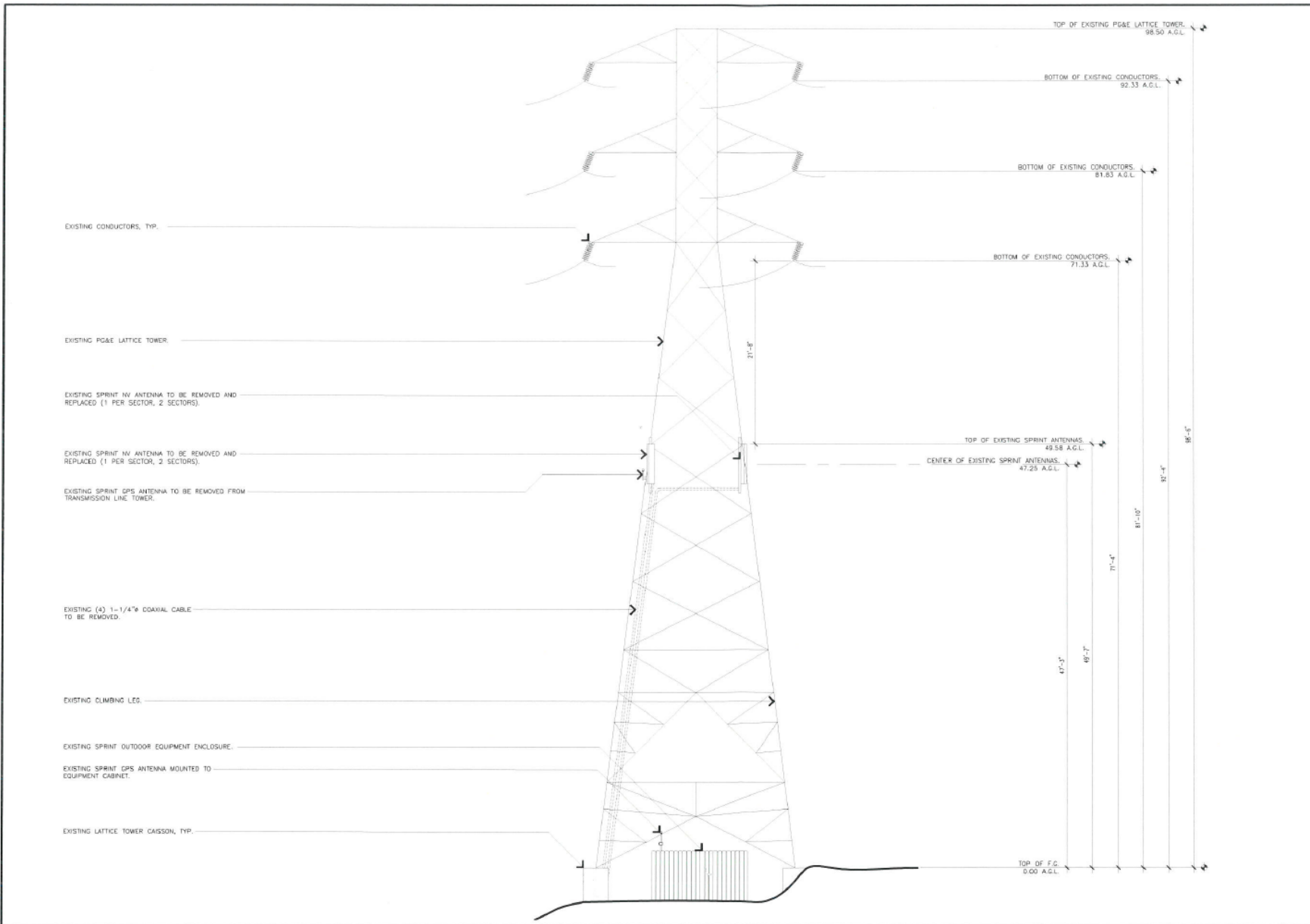

EXISTING SOUTHEAST ELEVATION

11x17 SCALE: 3/32"=1'-0"  
 22x34 SCALE: 3/16"=1'-0"  
 0 3' 6' 12' 1



6580 SPRINT PARKWAY  
 OVERLAND PARK, KANSAS 66251



**Jeffrey Rome** ASSOCIATES  
 architecture | telecommunications  
 131 Innovation Drive, Suite 100  
 Irvine, California 92617  
 tel 949.760.3929 | fax 949.760.3553

STAMP



**PROPRIETARY INFORMATION**  
 THE INFORMATION CONTAINED IN THIS SET OF CONSTRUCTION DOCUMENTS IS PROPRIETARY BY NATURE. ANY USE OR DISCLOSURE OTHER THAN THAT WHICH RELATES TO SPRINT IS STRICTLY PROHIBITED.

REVISIONS				
DESCRIPTION	DATE	BY	REV	
PG&E REDLINES 2	07/10/17	ZN	2	
GPS ANTENNA	08/10/17	RN	3	
CM COMMENTS	09/15/17	BV	4	
PG&E COMMENTS	09/29/17	BV	5	
PG&E COMMENTS 2	10/06/17	ZN	6	
4-PORT 800 SRU	11/17/17	RN	7	

NOT FOR CONSTRUCTION UNLESS LABELED AS CONSTRUCTION SET

PROJECT NAME  
**DO MACRO UPGRADE**  
 SITE NAME  
**JEFFERSON & SNEATH/MARTIN**  
 SITE CASCADE  
**FS04XC063**  
 323 SKYLINE BOULEVARD  
 BURLINGAME, CALIFORNIA 94010

SHEET TITLE  
**EXISTING SOUTHEAST ELEVATION**

**A-4**

## San Mateo County Zoning Hearing Officer Meeting

Owner/Applicant:

Attachment:

File Numbers:



**PROPRIETARY INFORMATION**  
THE INFORMATION CONTAINED IN THIS SET OF CONSTRUCTION DOCUMENTS IS PROPRIETARY BY NATURE. ANY USE OR DISCLOSURE OTHER THAN THAT WHICH RELATES TO SPRINT IS STRICTLY PROHIBITED.

REVISIONS				
DESCRIPTION	DATE	BY	REV	
PG&E REDLINES 2	07/10/17	ZN	2	
GPS ANTENNA	08/10/17	RN	3	
CM COMMENTS	09/15/17	BV	4	
PG&E COMMENTS	09/29/17	BV	5	
PG&E COMMENTS 2	10/06/17	ZN	6	
4-PORT 800 RRU	11/17/17	RN	7	

NOT FOR CONSTRUCTION UNLESS LABELED AS CONSTRUCTION SET

PROJECT NAME  
**DO MACRO UPGRADE**  
SITE NAME  
**JEFFERSON & SNEATH/MARTIN**  
SITE CASCADE  
**FS04XC063**  
323 SKYLINE BOULEVARD  
BURLINGAME, CALIFORNIA 94010

SHEET TITLE

**PROPOSED SOUTHEAST ELEVATION**

**A-4.1**

JRA JOB NUMBER: 16-023

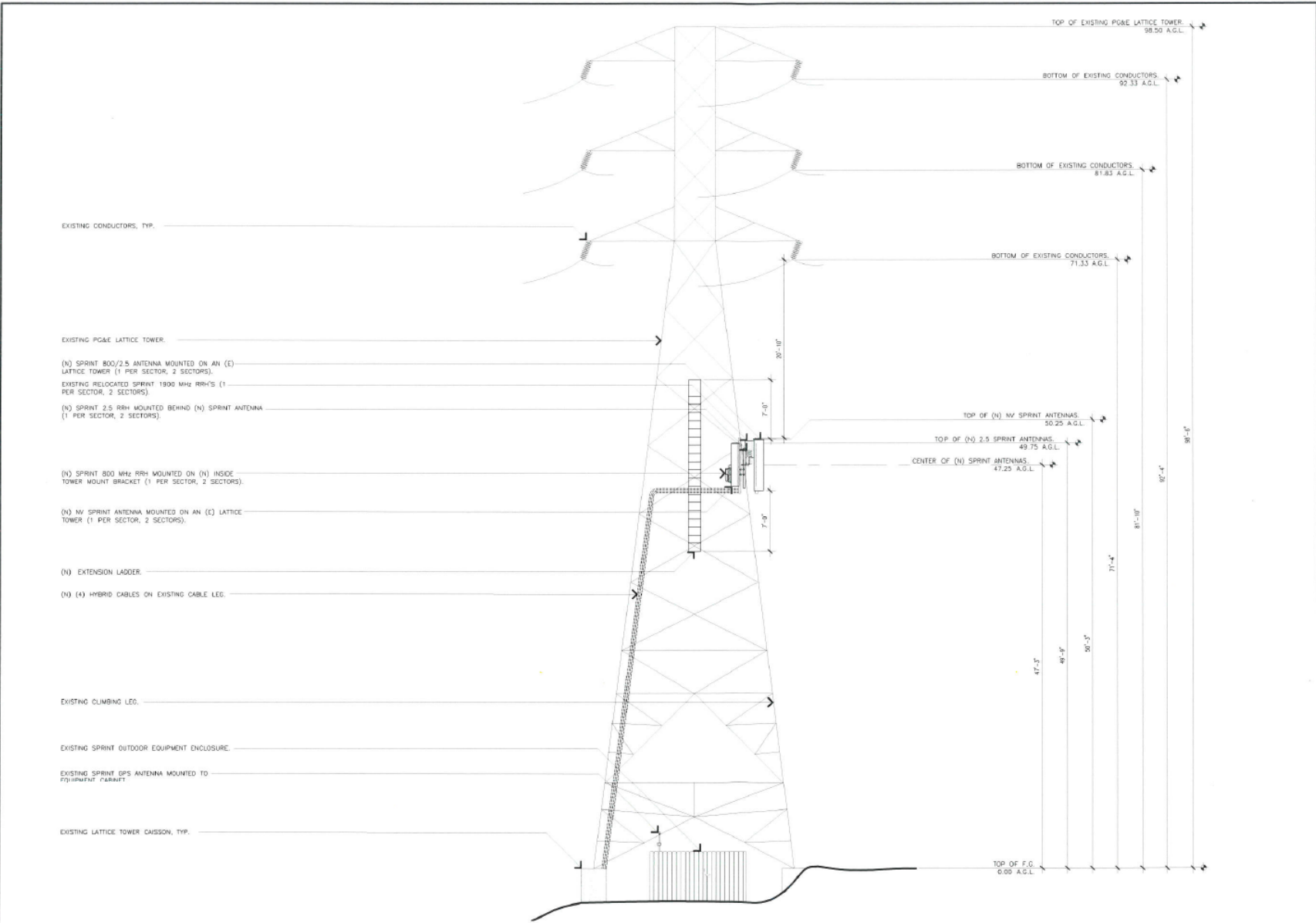

(N) SOUTHEAST ELEVATION

11x17 SCALE: 3/32"=1'-0"  
22x34 SCALE: 3/16"=1'-0"  
0 3' 6' 12'  
**1**

**San Mateo County Zoning Hearing Officer Meeting**

Owner/Applicant: \_\_\_\_\_ Attachment: \_\_\_\_\_  
File Numbers: \_\_\_\_\_

STAMP



**PROPRIETARY INFORMATION**  
THE INFORMATION CONTAINED IN THIS SET OF CONSTRUCTION DOCUMENTS IS PROPRIETARY BY NATURE. ANY USE OR DISCLOSURE OTHER THAN THAT WHICH RELATES TO SPRINT IS STRICTLY PROHIBITED.

DESCRIPTION	DATE	BY	REV
PG&E REDLINES 2	07/10/17	ZN	2
GPS ANTENNA	08/10/17	RN	3
CM COMMENTS	09/15/17	BN	4
PG&E COMMENTS	09/29/17	BN	5
PG&E COMMENTS 2	10/06/17	ZN	6
4-PORT 800 RRU	11/12/17	RN	7

NOT FOR CONSTRUCTION UNLESS LABELED AS CONSTRUCTION SET

PROJECT NAME  
**DO MACRO UPGRADE**  
SITE NAME  
**JEFFERSON & SNEATH/MARTIN**  
SITE CASCADE  
**FS04XC063**  
323 SKYLINE BOULEVARD  
BURLINGAME, CALIFORNIA 94010

SHEET TITLE  
**EXISTING NORTHEAST ELEVATION**

**A-5**

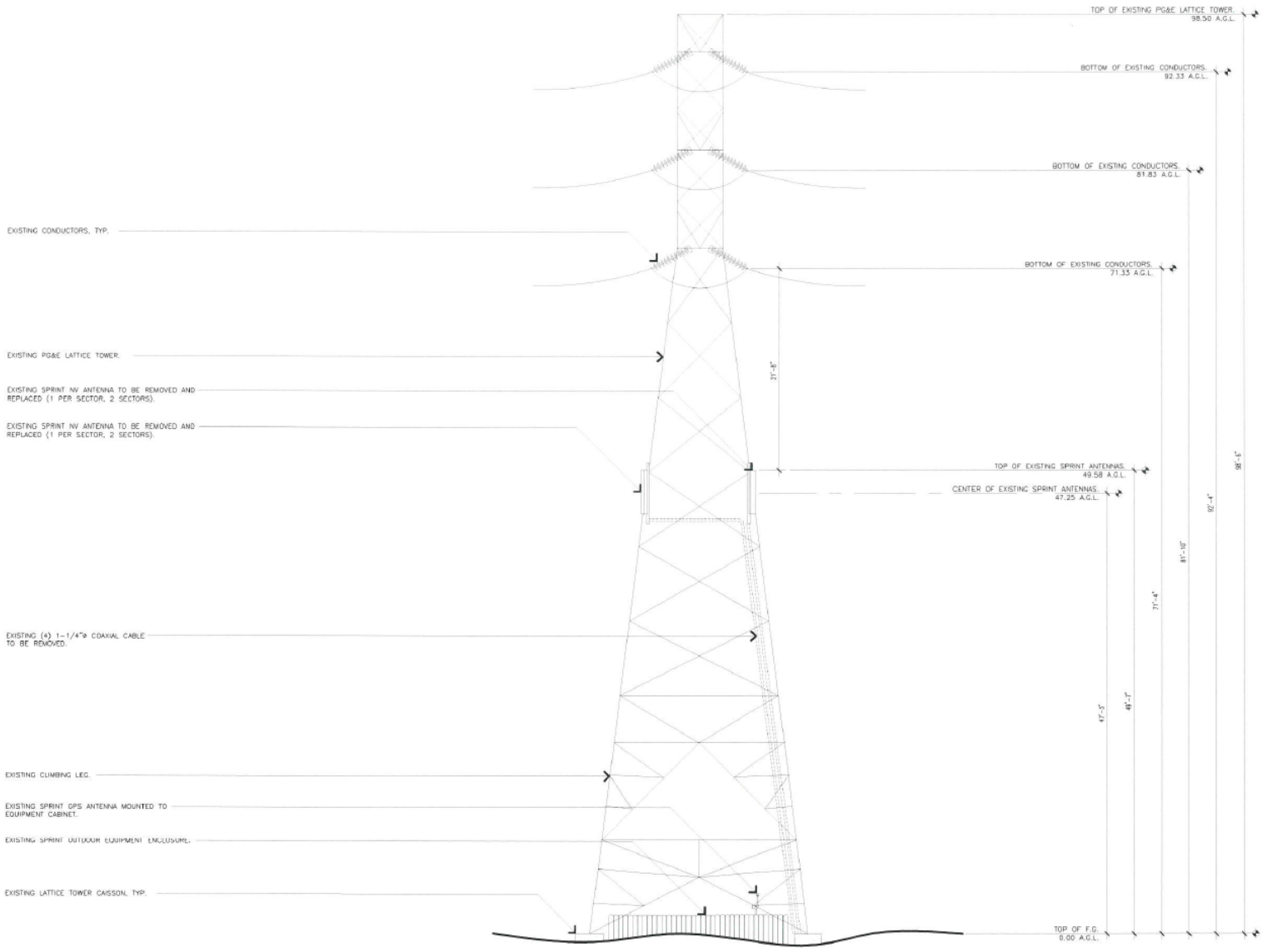

EXISTING NORTHEAST ELEVATION

11x17 SCALE: 3/32"=1'-0"  
22x34 SCALE: 3/16"=1'-0"  
0 3' 6' 12'  
**1**

**San Mateo County Zoning Hearing Officer Meeting**

Owner/Applicant:

Attachment:

File Numbers:

JRA JOB NUMBER: 18028



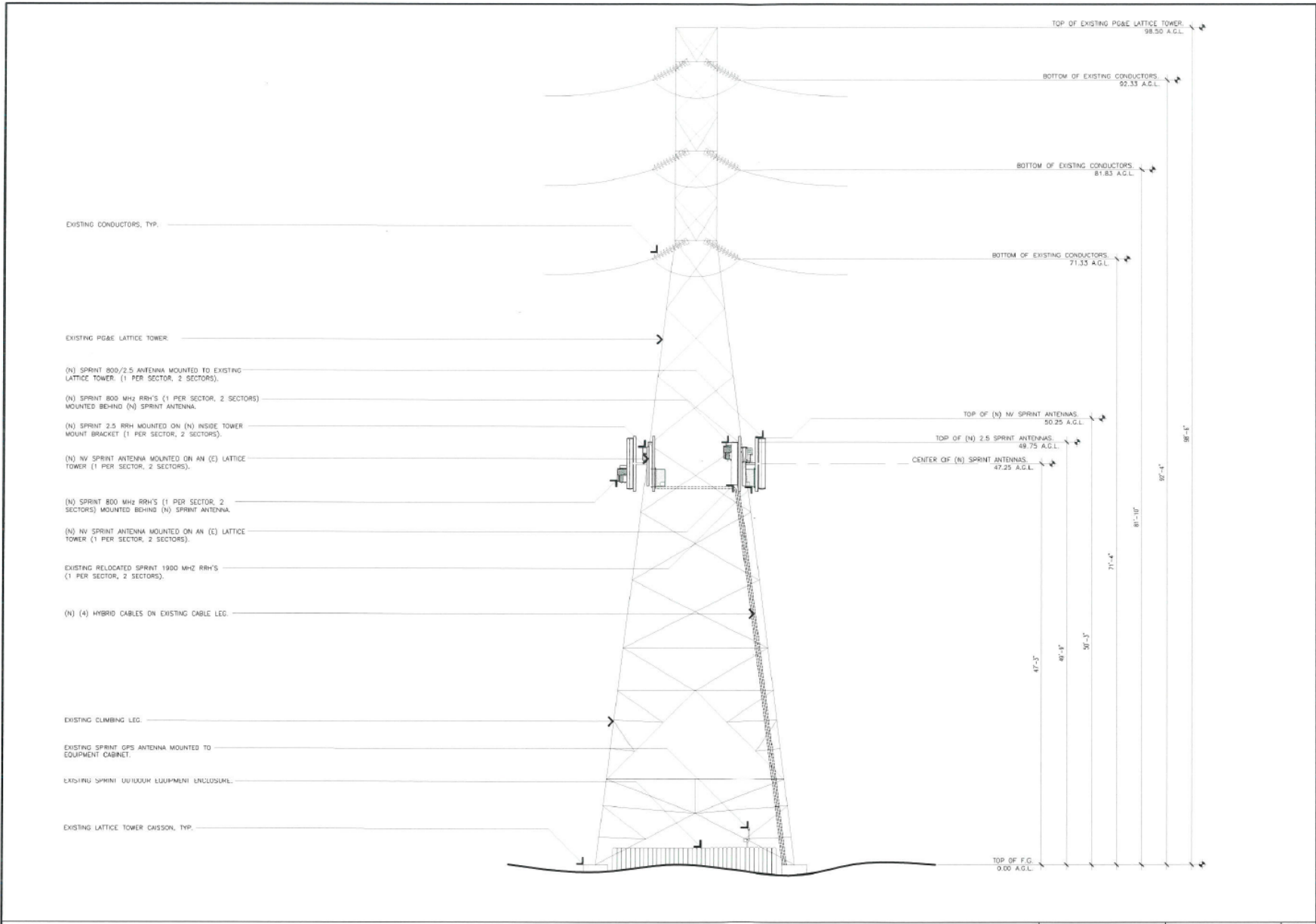

(N) NORTHEAST ELEVATION

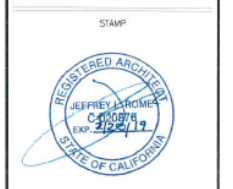

**PROPRIETARY INFORMATION**  
THE INFORMATION CONTAINED IN THIS SET OF CONSTRUCTION DOCUMENTS IS PROPRIETARY BY NATURE. ANY USE OR DISCLOSURE OTHER THAN THAT WHICH RELATES TO SPRINT IS STRICTLY PROHIBITED.

REVISIONS				
DESCRIPTION	DATE	BY	REV	
PG&E REDLINES 2	07/10/17	ZN	2	
GPS ANTENNA	08/10/17	RN	3	
CM COMMENTS	08/15/17	BN	4	
PG&E COMMENTS	09/29/17	BN	5	
PG&E COMMENTS 2	10/06/17	ZN	6	
4-PORT 800 RRU	11/17/17	RN	7	

NOT FOR CONSTRUCTION UNLESS LABELED AS CONSTRUCTION SET

PROJECT NAME  
**DO MACRO UPGRADE**

SITE NAME  
**JEFFERSON & SNEATH/MARTIN**

SITE CASCADE  
**FS04XC063**

323 SKYLARK BOULEVARD  
BURLINGAME, CALIFORNIA 94010

SHEET TITLE  
**PROPOSED NORTHEAST ELEVATION**

**A-5.1**

# San Mateo County Zoning Hearing Officer Meeting

Owner/Applicant: \_\_\_\_\_ Attachment: \_\_\_\_\_

File Numbers: \_\_\_\_\_

JRA\_CDR NUMBER: 161618

STAMP



**PROPRIETARY INFORMATION**  
 THE INFORMATION CONTAINED IN THIS SET OF CONSTRUCTION DOCUMENTS IS PROPRIETARY BY NATURE. ANY USE OR DISCLOSURE OTHER THAN THAT WHICH RELATES TO SPRINT IS STRICTLY PROHIBITED.

DESCRIPTION	REVISIONS		
	DATE	BY	REV
PG&E REDLINES 2	07/10/17	ZN	2
GRS ANTENNA	08/10/17	RN	3
CM COMMENTS	09/15/17	BN	4
PG&E COMMENTS	09/29/17	BN	5
PG&E COMMENTS 2	10/06/17	ZN	6
4-PORT 800 RRU	11/12/17	RN	7

NOT FOR CONSTRUCTION UNLESS LABELED AS CONSTRUCTION SET

PROJECT NAME  
**DO MACRO UPGRADE**  
 SITE NAME  
**JEFFERSON & SNEATH/MARTIN**  
 SITE CASCADE  
**F504XC063**  
 323 SKYLINE BOULEVARD  
 BURLINGAME, CALIFORNIA 94010

SHEET TITLE

**ANTENNA MOUNT DETAILS**

**A-6**

SEA, JOB NUMBER: 11628

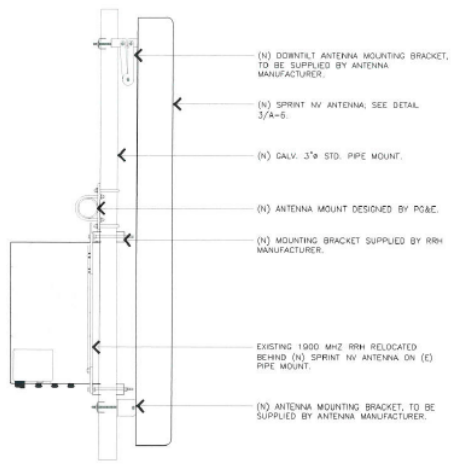

**NV ANTENNA AND RRH MOUNTING DETAIL**

SCALE: NONE **6**

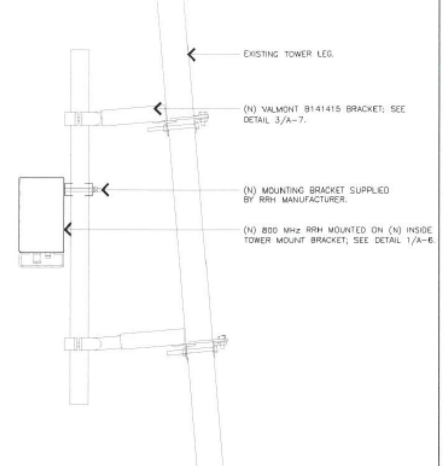

**RRH MOUNTING DETAIL**

SCALE: NONE **4**

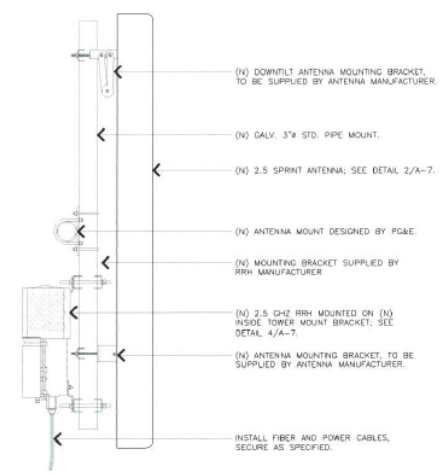

**ANTENNA AND RRH MOUNTING DETAIL**

SCALE: NONE **2**

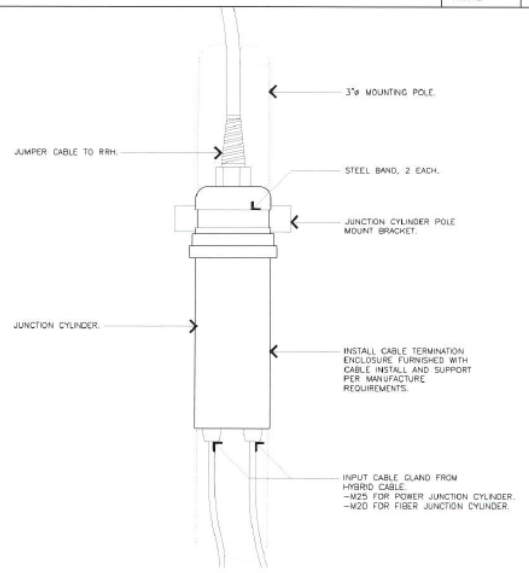

**POWER & FIBER JUNCTION CYLINDER**

SCALE: NONE **5**

**KMW ANTENNA ET-X-TS-70-15-62-18-IR-RD**

DIMENSIONS, HWWD: 1829x300x150mm  
 (72"x12"x5.9")  
 WEIGHT, WITH PRE-MOUNTED BRACKETS: 50 lbs  
 CONNECTOR: (8) 7/16 DIN FEMALE  
 FREQUENCY RANGE: 805-868 MHz  
 1850-1995 MHz

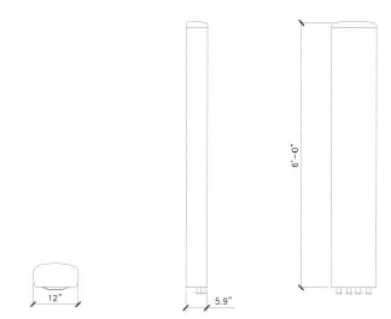

**NV ANTENNA SPECIFICATIONS**

SCALE: NONE **3**

**SAMSUNG 800 MHz RRU**

MANUFACTURER: SAMSUNG  
 MODEL: RF001F-26A  
 DIMENSIONS, HWWD: 12.59"x7.68"x12.59"  
 WEIGHT: 48.5 lbs.

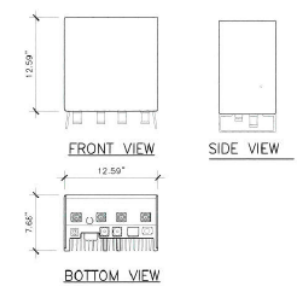

**800 MHz RRU SPECIFICATIONS**

SCALE: NONE **1**

**San Mateo County Zoning Hearing Officer Meeting**

Owner/Applicant:

Attachment:

File Numbers:

**SAMSUNG 2.5 GHz RRH**

MANUFACTURER: SAMSUNG  
 DIMENSIONS, HxWxD: 21.26"x15.03"x8.03"  
 WEIGHT: 53 lbs.  
 WEIGHT W/ BRACKET: 65 lbs.

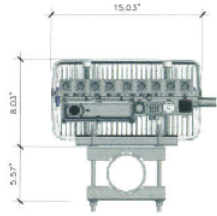

BOTTOM VIEW

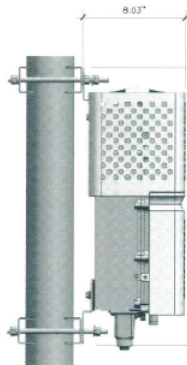

SIDE VIEW

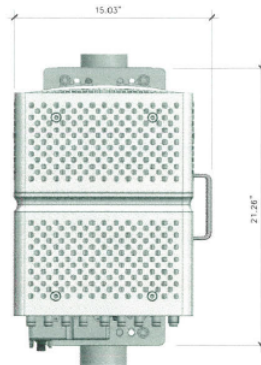

FRONT VIEW

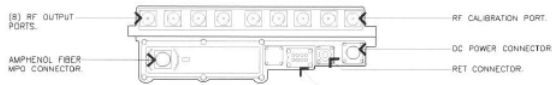

PORT LAYOUT PLAN

**NOTES:**  
 COMPLY WITH MANUFACTURER'S INSTRUCTIONS TO ENSURE THAT ALL RRH'S RECEIVE ELECTRICAL POWER WITHIN 24 HOURS OF BEING REMOVED FROM THE MANUFACTURER'S PACKAGING. DO NOT OPEN RRH PACKAGES IN THE RAIN.

**COMMSCOPE ANTENNA DT465B-2XR**

RADOME MATERIAL: FIBERGLASS  
 RADOME COLOR: LIGHT GRAY  
 DIMENSIONS, HxWxD: 71.9"x13.8"x8.2"  
 (1825x350x209mm)  
 WEIGHT, WITH PRE-MOUNTED BRACKETS: 58 lbs  
 CONNECTOR: 800 MHz - 7/16 DIN FEMALE, BOTTOM 2  
 2500 MHz - 4.1/9.5 DIN FEMALE, BOTTOM 8



PLAN VIEW



SIDE VIEW



FRONT VIEW

**2.5 GHz RRH**

SCALE: NONE

**4**

**800/2.5 ANTENNA**

SCALE: NONE

**2**

**PARTS LIST**

SYMBOL	DESCRIPTION	QTY
1	VALMONT B139409	1
2	VALMONT B1709	1
3	VALMONT B141415	1
4	PG&E "H" BRACKET MOUNT DETAIL	1

**HARDWARE LIST**

SYMBOL	DESCRIPTION	QTY
1	1/2" DIA. X 1 1/2" LONG 304 SS BOLT	400
2	1/2" DIA. X 1 1/2" LONG 304 SS BOLT	400
3	1/2" DIA. X 1 1/2" LONG 304 SS BOLT	400
4	1/2" DIA. X 1 1/2" LONG 304 SS BOLT	400
5	1/2" DIA. X 1 1/2" LONG 304 SS BOLT	400
6	1/2" DIA. X 1 1/2" LONG 304 SS BOLT	400
7	1/2" DIA. X 1 1/2" LONG 304 SS BOLT	400
8	1/2" DIA. X 1 1/2" LONG 304 SS BOLT	400
9	1/2" DIA. X 1 1/2" LONG 304 SS BOLT	400
10	1/2" DIA. X 1 1/2" LONG 304 SS BOLT	400
11	1/2" DIA. X 1 1/2" LONG 304 SS BOLT	400
12	1/2" DIA. X 1 1/2" LONG 304 SS BOLT	400
13	1/2" DIA. X 1 1/2" LONG 304 SS BOLT	400
14	1/2" DIA. X 1 1/2" LONG 304 SS BOLT	400
15	1/2" DIA. X 1 1/2" LONG 304 SS BOLT	400
16	1/2" DIA. X 1 1/2" LONG 304 SS BOLT	400
17	1/2" DIA. X 1 1/2" LONG 304 SS BOLT	400
18	1/2" DIA. X 1 1/2" LONG 304 SS BOLT	400
19	1/2" DIA. X 1 1/2" LONG 304 SS BOLT	400
20	1/2" DIA. X 1 1/2" LONG 304 SS BOLT	400
21	1/2" DIA. X 1 1/2" LONG 304 SS BOLT	400
22	1/2" DIA. X 1 1/2" LONG 304 SS BOLT	400
23	1/2" DIA. X 1 1/2" LONG 304 SS BOLT	400
24	1/2" DIA. X 1 1/2" LONG 304 SS BOLT	400
25	1/2" DIA. X 1 1/2" LONG 304 SS BOLT	400
26	1/2" DIA. X 1 1/2" LONG 304 SS BOLT	400
27	1/2" DIA. X 1 1/2" LONG 304 SS BOLT	400
28	1/2" DIA. X 1 1/2" LONG 304 SS BOLT	400
29	1/2" DIA. X 1 1/2" LONG 304 SS BOLT	400
30	1/2" DIA. X 1 1/2" LONG 304 SS BOLT	400
31	1/2" DIA. X 1 1/2" LONG 304 SS BOLT	400
32	1/2" DIA. X 1 1/2" LONG 304 SS BOLT	400
33	1/2" DIA. X 1 1/2" LONG 304 SS BOLT	400
34	1/2" DIA. X 1 1/2" LONG 304 SS BOLT	400
35	1/2" DIA. X 1 1/2" LONG 304 SS BOLT	400
36	1/2" DIA. X 1 1/2" LONG 304 SS BOLT	400
37	1/2" DIA. X 1 1/2" LONG 304 SS BOLT	400
38	1/2" DIA. X 1 1/2" LONG 304 SS BOLT	400
39	1/2" DIA. X 1 1/2" LONG 304 SS BOLT	400
40	1/2" DIA. X 1 1/2" LONG 304 SS BOLT	400
41	1/2" DIA. X 1 1/2" LONG 304 SS BOLT	400
42	1/2" DIA. X 1 1/2" LONG 304 SS BOLT	400
43	1/2" DIA. X 1 1/2" LONG 304 SS BOLT	400
44	1/2" DIA. X 1 1/2" LONG 304 SS BOLT	400
45	1/2" DIA. X 1 1/2" LONG 304 SS BOLT	400
46	1/2" DIA. X 1 1/2" LONG 304 SS BOLT	400
47	1/2" DIA. X 1 1/2" LONG 304 SS BOLT	400
48	1/2" DIA. X 1 1/2" LONG 304 SS BOLT	400
49	1/2" DIA. X 1 1/2" LONG 304 SS BOLT	400
50	1/2" DIA. X 1 1/2" LONG 304 SS BOLT	400
51	1/2" DIA. X 1 1/2" LONG 304 SS BOLT	400
52	1/2" DIA. X 1 1/2" LONG 304 SS BOLT	400
53	1/2" DIA. X 1 1/2" LONG 304 SS BOLT	400
54	1/2" DIA. X 1 1/2" LONG 304 SS BOLT	400
55	1/2" DIA. X 1 1/2" LONG 304 SS BOLT	400
56	1/2" DIA. X 1 1/2" LONG 304 SS BOLT	400
57	1/2" DIA. X 1 1/2" LONG 304 SS BOLT	400
58	1/2" DIA. X 1 1/2" LONG 304 SS BOLT	400
59	1/2" DIA. X 1 1/2" LONG 304 SS BOLT	400
60	1/2" DIA. X 1 1/2" LONG 304 SS BOLT	400
61	1/2" DIA. X 1 1/2" LONG 304 SS BOLT	400
62	1/2" DIA. X 1 1/2" LONG 304 SS BOLT	400
63	1/2" DIA. X 1 1/2" LONG 304 SS BOLT	400
64	1/2" DIA. X 1 1/2" LONG 304 SS BOLT	400
65	1/2" DIA. X 1 1/2" LONG 304 SS BOLT	400
66	1/2" DIA. X 1 1/2" LONG 304 SS BOLT	400
67	1/2" DIA. X 1 1/2" LONG 304 SS BOLT	400
68	1/2" DIA. X 1 1/2" LONG 304 SS BOLT	400
69	1/2" DIA. X 1 1/2" LONG 304 SS BOLT	400
70	1/2" DIA. X 1 1/2" LONG 304 SS BOLT	400
71	1/2" DIA. X 1 1/2" LONG 304 SS BOLT	400
72	1/2" DIA. X 1 1/2" LONG 304 SS BOLT	400
73	1/2" DIA. X 1 1/2" LONG 304 SS BOLT	400
74	1/2" DIA. X 1 1/2" LONG 304 SS BOLT	400
75	1/2" DIA. X 1 1/2" LONG 304 SS BOLT	400
76	1/2" DIA. X 1 1/2" LONG 304 SS BOLT	400
77	1/2" DIA. X 1 1/2" LONG 304 SS BOLT	400
78	1/2" DIA. X 1 1/2" LONG 304 SS BOLT	400
79	1/2" DIA. X 1 1/2" LONG 304 SS BOLT	400
80	1/2" DIA. X 1 1/2" LONG 304 SS BOLT	400
81	1/2" DIA. X 1 1/2" LONG 304 SS BOLT	400
82	1/2" DIA. X 1 1/2" LONG 304 SS BOLT	400
83	1/2" DIA. X 1 1/2" LONG 304 SS BOLT	400
84	1/2" DIA. X 1 1/2" LONG 304 SS BOLT	400
85	1/2" DIA. X 1 1/2" LONG 304 SS BOLT	400
86	1/2" DIA. X 1 1/2" LONG 304 SS BOLT	400
87	1/2" DIA. X 1 1/2" LONG 304 SS BOLT	400
88	1/2" DIA. X 1 1/2" LONG 304 SS BOLT	400
89	1/2" DIA. X 1 1/2" LONG 304 SS BOLT	400
90	1/2" DIA. X 1 1/2" LONG 304 SS BOLT	400
91	1/2" DIA. X 1 1/2" LONG 304 SS BOLT	400
92	1/2" DIA. X 1 1/2" LONG 304 SS BOLT	400
93	1/2" DIA. X 1 1/2" LONG 304 SS BOLT	400
94	1/2" DIA. X 1 1/2" LONG 304 SS BOLT	400
95	1/2" DIA. X 1 1/2" LONG 304 SS BOLT	400
96	1/2" DIA. X 1 1/2" LONG 304 SS BOLT	400
97	1/2" DIA. X 1 1/2" LONG 304 SS BOLT	400
98	1/2" DIA. X 1 1/2" LONG 304 SS BOLT	400
99	1/2" DIA. X 1 1/2" LONG 304 SS BOLT	400
100	1/2" DIA. X 1 1/2" LONG 304 SS BOLT	400

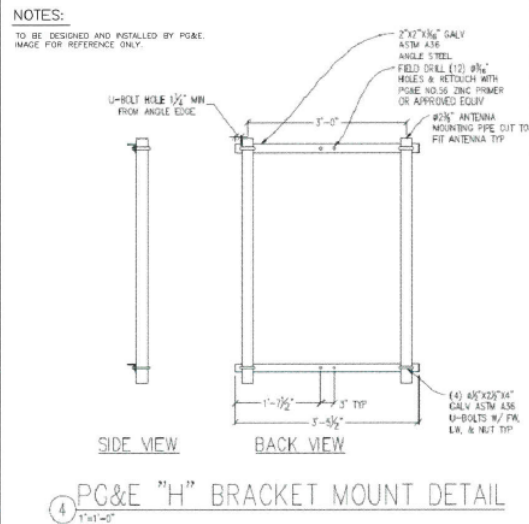
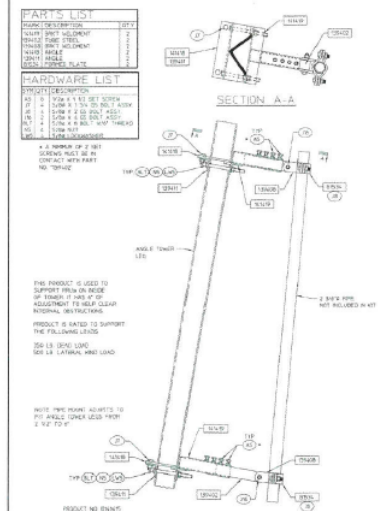
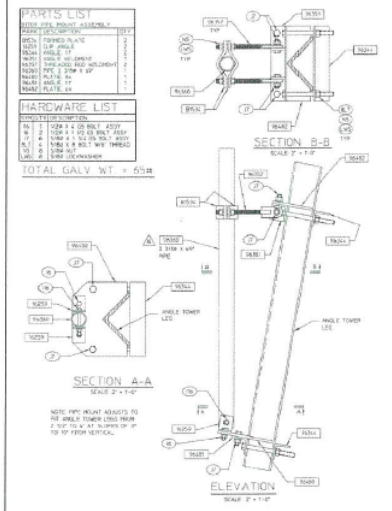
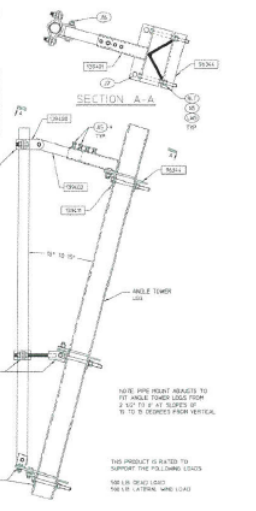

VALMONT B139409 SCALE: NONE **6**

VALMONT B1709 SCALE: NONE **5**

VALMONT B141415 SCALE: NONE **3**

PG&E "H" BRACKET MOUNT DETAIL SCALE: NONE **1**



6580 SPRINT PARKWAY  
 OVERLAND PARK, KANSAS 66251



**Jeffrey Rome Associates**  
 architecture | telecommunications  
 131 Innovation Drive, Suite 100  
 Irvine, California 92617  
 tel 949.760.3928 / fax 949.760.3933



**PROPRIETARY INFORMATION**  
 THE INFORMATION CONTAINED IN THIS SET OF CONSTRUCTION DOCUMENTS IS PROPRIETARY BY NATURE. ANY USE OR DISCLOSURE OTHER THAN THAT WHICH RELATES TO SPRINT IS STRICTLY PROHIBITED.

DESCRIPTION	REVISIONS	DATE	BY	REV
PG&E REDLINES 2	07/10/17	ZN	2	
OPS ANTENNA	08/16/17	RN	3	
CM COMMENTS	09/15/17	BV	4	
PG&E COMMENTS	09/28/17	BV	5	
PG&E COMMENTS 2	10/08/17	ZN	6	
4-PORT 800 RRU	11/17/17	RN	7	

PROJECT NAME: **DO MACRO UPGRADE**  
 SITE NAME: **JEFFERSON & SNEATH/MARTIN**  
 SITE CASCADE: **FS04XC063**  
 323 SKYLINE BOULEVARD  
 BURLINGAME, CALIFORNIA 94010

SHEET TITLE: **EQUIPMENT DETAILS**

**A-7**

**San Mateo County Zoning Hearing Officer Meeting**

Owner/Applicant: \_\_\_\_\_

File Numbers: \_\_\_\_\_

Attachment: \_\_\_\_\_



View of Existing Tower From Northbound I-280

***San Mateo County Zoning Hearing Officer Meeting***

Owner/Applicant:

Attachment:

File Numbers:



Existing PG&E Tower

***San Mateo County Zoning Hearing Officer Meeting***

Owner/Applicant:

Attachment:

File Numbers:

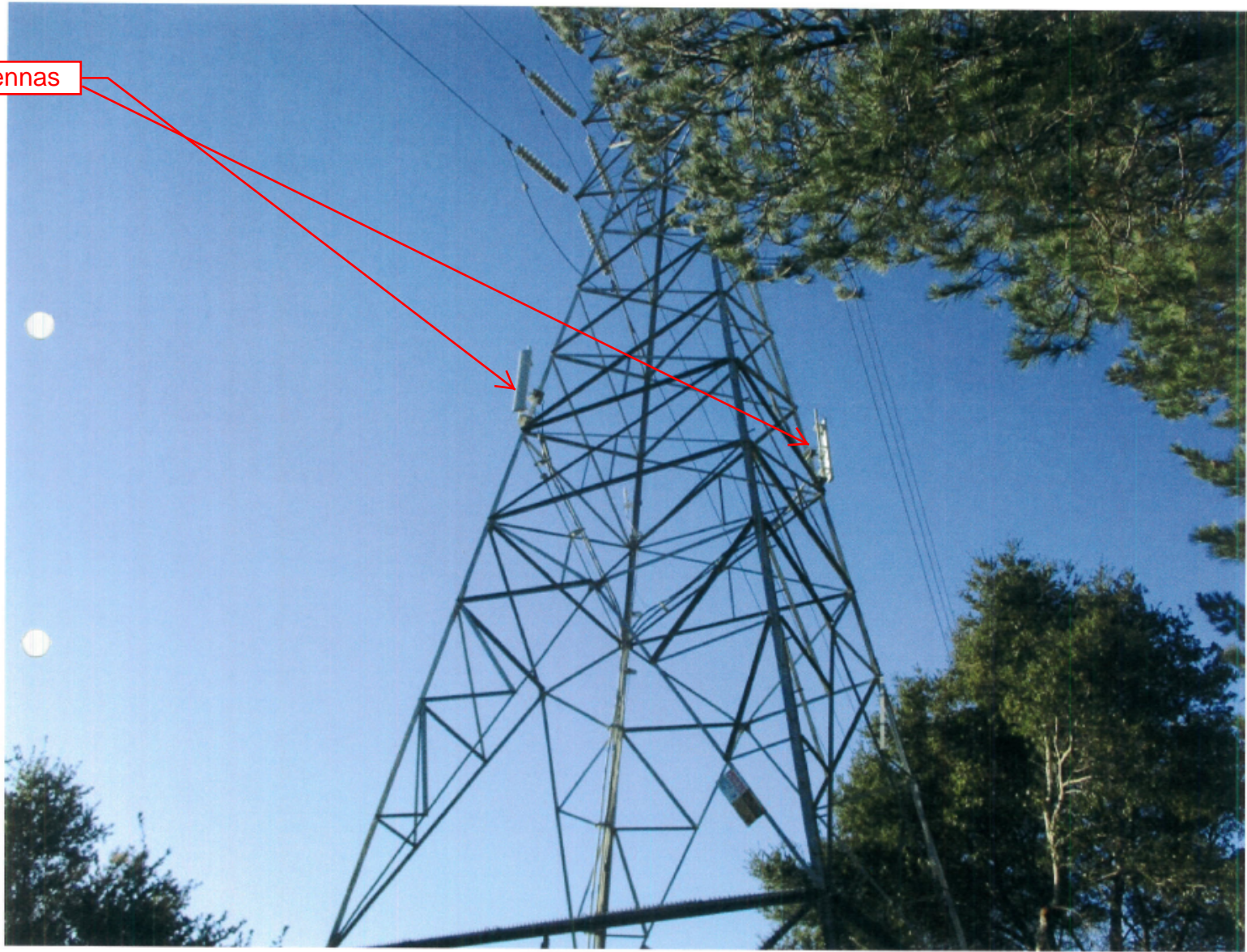

Existing Antennas

***San Mateo County Zoning Hearing Officer Meeting***

Owner/Applicant:

Attachment:

File Numbers:



Existing Equipment Storage Area

***San Mateo County Zoning Hearing Officer Meeting***

Owner/Applicant: \_\_\_\_\_

Attachment: \_\_\_\_\_

File Numbers: \_\_\_\_\_



Equipment Storage Area

***San Mateo County Zoning Hearing Officer Meeting***

Owner/Applicant: \_\_\_\_\_

Attachment: \_\_\_\_\_

File Numbers: \_\_\_\_\_



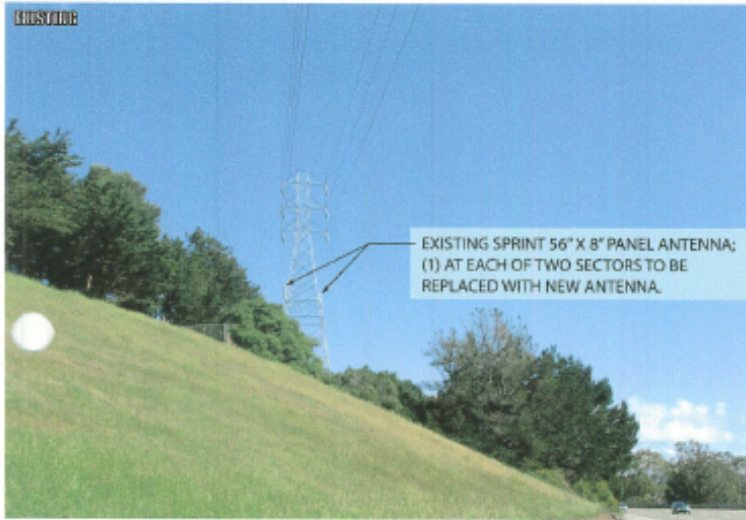

Photosimulation Viewpoint

Photosimulation of proposed telecommunications site

<p><b>JEFFREY ROME   ASSOCIATES</b> ARCHITECTURE   PLANNING/CONSULTING 101 9TH FLOOR   1000 PIERCE DRIVE 331   IRVINE/COSTA MESA   SUITE 300 IRVINE, CALIFORNIA 92617</p>	<p><b>SPRINT DO ESS PROJECT</b> <b>FS04XC063</b> <b>JEFFERSON &amp; SNEATH/MARTIN</b> 323 Skyline Drive Burlingame, CA 94010</p>
---	--

## Photo Simulations

### San Mateo County Zoning Hearing Officer Meeting

Owner/Applicant: \_\_\_\_\_

Attachment: \_\_\_\_\_

File Numbers: \_\_\_\_\_



**SITE SAFE**  
RF COMPLIANCE EXPERTS

A BUSINESS OF FDH VELOCITEL

200 North Glebe Road, Suite 1000, Arlington, VA 22203-3728  
703.276.1100 • 703.276.1169 fax  
info@sitesafe.com • www.sitesafe.com

**Jeffrey Rome & Associates on  
behalf of Sprint  
Site ID – FS04XC063  
Site Name – Jefferson &  
Sneath/Martin  
Site Compliance Report**

**323 Skyline Drive  
Burlingame, CA 94010**

Latitude: N37-34-27.62  
Longitude: W122-23-58.06  
Structure Type: Self-Support

Report generated date: November 13, 2017  
Report by: Mohamed Frej  
Customer Contact: Robin Nelson

**Sprint is compliant and will remain compliant  
upon implementation of the proposed  
changes.**

© 2017 Sitesafe, Inc. Arlington, VA



*Klaus Bender*

Klaus Bender  
Registered Professional Engineer (Electrical)  
State of California, 18131, Expires 2019-June-30  
Date Signed: 2017-November-15

**RECEIVED**

DEC 26 REC'D

San Mateo County  
Planning and Building Department

**San Mateo County Zoning Hearing Officer Meeting**

Owner/Applicant: \_\_\_\_\_

Attachment: \_\_\_\_\_

File Numbers: \_\_\_\_\_



## 1 Executive Summary

Sprint has contracted with Sitesafe, Inc. (Sitesafe), an independent Radio Frequency (RF) regulatory and engineering consulting firm, to determine whether the proposed communications site, FS04XC063 - Jefferson & Sneath/Martin, located at 323 Skyline Drive, Burlingame, CA, is in compliance with Federal Communication Commission (FCC) Rules and Regulations for RF emissions.

This report contains a detailed summary of the RF environment at the site including:

- Diagram of the site
- Inventory of the make / model of all antennas
- Theoretical MPE based on modeling

This report addresses exposure to radio frequency electromagnetic fields in accordance with the FCC Rules and Regulations for all individuals, classified in two groups, "Occupational or Controlled" and "General Public or Uncontrolled."

**Sprint is compliant with the FCC rules and regulations, as described in OET Bulletin 65 and will remain compliant upon implementation of the proposed changes.**

This document and the conclusions herein are based on the information provided by Sprint.

If you have any questions regarding RF safety and regulatory compliance, please do not hesitate to contact Sitesafe's Customer Support Department at (703) 276-1100.

### **San Mateo County Zoning Hearing Officer Meeting**

Owner/Applicant: \_\_\_\_\_

Attachment: \_\_\_\_\_

File Numbers: \_\_\_\_\_



## Table of Contents

<b>1 EXECUTIVE SUMMARY .....</b>	<b>3</b>
<b>2 REGULATORY BASIS .....</b>	<b>4</b>
2.1 FCC RULES AND REGULATIONS .....	4
2.2 OSHA STATEMENT .....	5
<b>3 SITE COMPLIANCE .....</b>	<b>6</b>
3.1 SITE COMPLIANCE STATEMENT .....	6
3.2 ACTIONS FOR SITE COMPLIANCE .....	6
<b>4 SAFETY PLAN AND PROCEDURES .....</b>	<b>7</b>
<b>5 ANALYSIS .....</b>	<b>8</b>
5.1 RF EMISSIONS DIAGRAM .....	8
<b>6 ANTENNA INVENTORY .....</b>	<b>12</b>
<b>7 ENGINEER CERTIFICATION .....</b>	<b>14</b>
<b>APPENDIX A – STATEMENT OF LIMITING CONDITIONS .....</b>	<b>15</b>
<b>APPENDIX B – ASSUMPTIONS AND DEFINITIONS .....</b>	<b>16</b>
GENERAL MODEL ASSUMPTIONS .....	16
USE OF GENERIC ANTENNAS .....	16
DEFINITIONS .....	17
<b>APPENDIX C – RULES &amp; REGULATIONS .....</b>	<b>19</b>
EXPLANATION OF APPLICABLE RULES AND REGULATIONS .....	19
OCCUPATIONAL ENVIRONMENT EXPLAINED .....	19
<b>APPENDIX D – GENERAL SAFETY RECOMMENDATIONS .....</b>	<b>20</b>
ADDITIONAL INFORMATION .....	21

---

200 N. Glebe Road • Suite 1000 • Arlington, VA 22203-3728  
703.276.1100 • info@sitesafe.com

### ***San Mateo County Zoning Hearing Officer Meeting***

Owner/Applicant: \_\_\_\_\_

Attachment: \_\_\_\_\_

File Numbers: \_\_\_\_\_



## 1 Executive Summary

Sprint has contracted with Sitesafe, Inc. (Sitesafe), an independent Radio Frequency (RF) regulatory and engineering consulting firm, to determine whether the proposed communications site, FSO4XC063 - Jefferson & Sneath/Martin, located at 323 Skyline Drive, Burlingame, CA, is in compliance with Federal Communication Commission (FCC) Rules and Regulations for RF emissions.

This report contains a detailed summary of the RF environment at the site including:

- Diagram of the site
- Inventory of the make / model of all antennas
- Theoretical MPE based on modeling

This report addresses exposure to radio frequency electromagnetic fields in accordance with the FCC Rules and Regulations for all individuals, classified in two groups, "Occupational or Controlled" and "General Public or Uncontrolled."

**Sprint is compliant** with the FCC rules and regulations, as described in OET Bulletin 65 **and will remain compliant upon implementation of the proposed changes.**

This document and the conclusions herein are based on the information provided by Sprint.

If you have any questions regarding RF safety and regulatory compliance, please do not hesitate to contact Sitesafe's Customer Support Department at (703) 276-1100.

### San Mateo County Zoning Hearing Officer Meeting

Owner/Applicant: \_\_\_\_\_

Attachment: \_\_\_\_\_

File Numbers: \_\_\_\_\_

## 2 Regulatory Basis

### 2.1 FCC Rules and Regulations

In 1996, the Federal Communication Commission (FCC) adopted regulations for the evaluating of the effects of RF emissions in 47 CFR § 1.1307 and 1.1310. The guideline from the FCC Office of Engineering and Technology is Bulletin 65 ("OET Bulletin 65"), *Evaluating Compliance with FCC Guidelines for Human Exposure to Radio Frequency Electromagnetic Fields*, Edition 97-01, published August 1997. Since 1996 the FCC periodically reviews these rules and regulations as per their congressional mandate.

FCC regulations define two separate tiers of exposure limits: Occupational or "Controlled environment" and General Public or "Uncontrolled environment". The General Public limits are generally five times more conservative or restrictive than the Occupational limit. These limits apply to accessible areas where workers or the general public may be exposed to Radio Frequency (RF) electromagnetic fields.

Occupational or Controlled limits apply in situations in which persons are exposed as a consequence of their employment and where those persons exposed have been made fully aware of the potential for exposure and can exercise control over their exposure.

An area is considered a Controlled environment when access is limited to these aware personnel. Typical criteria are restricted access (i.e. locked or alarmed doors, barriers, etc.) to the areas where antennas are located coupled with proper RF warning signage. A site with Controlled environments is evaluated with Occupational limits.

All other areas are considered Uncontrolled environments. If a site has no access controls or no RF warning signage it is evaluated with General Public limits.

The theoretical modeling of the RF electromagnetic fields has been performed in accordance with OET Bulletin 65. The Maximum Permissible Exposure (MPE) limits utilized in this analysis are outlined in the following diagram:

**FCC Limits for Maximum Permissible Exposure (MPE)**  
Plane-wave Equivalent Power Density

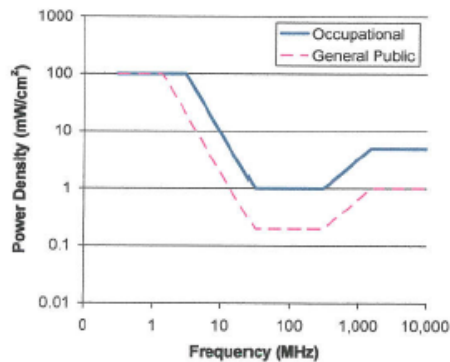

## San Mateo County Zoning Hearing Officer Meeting

Owner/Applicant:

Attachment:

File Numbers:



**Limits for Occupational/Controlled Exposure (MPE)**

Frequency Range (MHz)	Electric Field Strength (E) (V/m)	Magnetic Field Strength (H) (A/m)	Power Density (S) (mW/cm <sup>2</sup> )	Averaging Time  E  <sup>2</sup> ,  H  <sup>2</sup> or S (minutes)
0.3-3.0	614	1.63	(100)*	6
3.0-30	1842/f	4.89/f	(900/f <sup>2</sup> )*	6
30-300	61.4	0.163	1.0	6
300-1500	--	--	f/300	6
1500-100,000	--	--	5	6

**Limits for General Population/Uncontrolled Exposure (MPE)**

Frequency Range (MHz)	Electric Field Strength (E) (V/m)	Magnetic Field Strength (H) (A/m)	Power Density (S) (mW/cm <sup>2</sup> )	Averaging Time  E  <sup>2</sup> ,  H  <sup>2</sup> or S (minutes)
0.3-1.34	614	1.63	(100)*	30
1.34-30	824/f	2.19/f	(180/f <sup>2</sup> )*	30
30-300	27.5	0.073	0.2	30
300-1500	--	--	f/1500	30
1500-100,000	--	--	1.0	30

f = frequency in MHz      \*Plane-wave equivalent power density

**2.2 OSHA Statement**

The General Duty clause of the OSHA Act (Section 5) outlines the occupational safety and health responsibilities of the employer and employee. The General Duty clause in Section 5 states:

- (a) Each employer –
  - (1) shall furnish to each of his employees employment and a place of employment which are free from recognized hazards that are causing or are likely to cause death or serious physical harm to his employees;
  - (2) shall comply with occupational safety and health standards promulgated under this Act.
- (b) Each employee shall comply with occupational safety and health standards and all rules, regulations, and orders issued pursuant to this Act which are applicable to his own actions and conduct.

OSHA has defined Radiofrequency and Microwave Radiation safety standards for workers who may enter hazardous RF areas. Regulation Standards 29 CFR § 1910.147 identify a generic Lock Out Tag Out procedure aimed to control the unexpected energization or start up of machines when maintenance or service is being performed.

**San Mateo County Zoning Hearing Officer Meeting**

Owner/Applicant: \_\_\_\_\_

Attachment: \_\_\_\_\_

File Numbers: \_\_\_\_\_



### 3 Site Compliance

#### 3.1 Site Compliance Statement

Upon evaluation of the cumulative RF emission levels from all operators at this site, Sitesafe has determined that:

**Sprint is compliant** with the FCC rules and regulations, as described in OET Bulletin 65 **and will remain compliant upon implementation of the proposed changes.**

The compliance determination is based on theoretical modeling, RF signage placement recommendations, proposed antenna inventory and the level of restricted access to the antennas at the site. Any deviation from Sprint's proposed deployment plan could result in the site being rendered non-compliant.

#### 3.2 Actions for Site Compliance

Based on common industry practice and our understanding of FCC and OSHA requirements, this section provides a statement of recommendations for site compliance. RF alert signage recommendations have been proposed based on theoretical analysis of MPE levels. Barriers can consist of locked doors, fencing, railing, rope, chain, paint striping or tape, combined with RF alert signage.

Sprint is compliant with the FCC rules and regulations and will remain compliant upon implementation of the proposed changes.

## San Mateo County Zoning Hearing Officer Meeting

Owner/Applicant: \_\_\_\_\_

Attachment: \_\_\_\_\_

File Numbers: \_\_\_\_\_



#### 4 Safety Plan and Procedures

The following items are general safety recommendations that should be administered on a site by site basis as needed by the carrier.

**General Maintenance Work:** Any maintenance personnel required to work immediately in front of antennas and / or in areas indicated as above 100% of the Occupational MPE limits should coordinate with the wireless operators to disable transmitters during their work activities.

**Training and Qualification Verification:** All personnel accessing areas indicated as exceeding the General Population MPE limits should have a basic understanding of EME awareness and RF Safety procedures when working around transmitting antennas. Awareness training increases a workers understanding to potential RF exposure scenarios. Awareness can be achieved in a number of ways (e.g. videos, formal classroom lecture or internet based courses).

**Physical Access Control:** Access restrictions to transmitting antennas locations is the primary element in a site safety plan. Examples of access restrictions are as follows:

- Locked door or gate
- Alarmed door
- Locked ladder access
- Restrictive Barrier at antenna (e.g. Chain link with posted RF Sign)

**RF Signage:** Everyone should obey all posted signs at all times. RF signs play an important role in properly warning a worker prior to entering into a potential RF Exposure area.

**Assume all antennas are active:** Due to the nature of telecommunications transmissions, an antenna transmits intermittently. Always assume an antenna is transmitting. Never stop in front of an antenna. If you have to pass by an antenna, move through as quickly and safely as possible thereby reducing any exposure to a minimum.

**Maintain a 3 foot clearance from all antennas:** There is a direct correlation between the strength of an EME field and the distance from the transmitting antenna. The further away from an antenna, the lower the corresponding EME field is.

**Site RF Emissions Diagram:** Section 5 of this report contains an RF Diagram that outlines various theoretical Maximum Permissible Exposure (MPE) areas at the site. The modeling is a worst case scenario assuming a duty cycle of 100% for each transmitting antenna at full power. This analysis is based on one of two access control criteria: General Public criteria means the access to the site is uncontrolled and anyone can gain access. Occupational criteria means the access is restricted and only properly trained individuals can gain access to the antenna locations.

## San Mateo County Zoning Hearing Officer Meeting

Owner/Applicant:

Attachment:

File Numbers:

**5 Analysis**

**5.1 RF Emissions Diagram**

The RF diagram(s) below display theoretical spatially averaged percentage of the Maximum Permissible Exposure for all systems at the site unless otherwise noted. These diagrams use modeling as prescribed in OET Bulletin 65 and assumptions detailed in Appendix B.

The key at the bottom of each diagram indicates if percentages displayed are referenced to FCC General Population Maximum Permissible Exposure (MPE) limits. Color coding on the diagram is as follows:

- Gray represents areas predicted to be at 5% of the MPE limits, or below.
- Green represents areas predicted to be between 5% and 100% of the MPE limits.
- Blue represents areas predicted to be between 100% and 500% of the MPE limits.
- Yellow represents areas predicted to be between 500% and 5000% of the MPE limits.
- Red areas indicated predicted levels greater than 5000% of the MPE limits.

The theoretical analysis identified the maximum predicted MPE levels on the Ground Level to be:

Maximum Cumulative Theoretical General Public MPE level: <1%  
Maximum Sprint Theoretical General Public MPE level: <1%

General Population diagrams are specified when an area is accessible to the public; i.e. personnel that do not meet Occupational or RF Safety trained criteria, could gain access.

If trained occupational personnel require access to areas that are delineated as **Blue** or above 100% of the limit, Sitesafe recommends that they utilize the proper personal protection equipment (RF monitors), coordinate with the carriers to reduce or shutdown power, or make real-time power density measurements with the appropriate power density meter to determine real-time MPE levels. This will allow the personnel to ensure that their work area is within exposure limits.

The key at the bottom also indicates the level or height of the modeling with respect to the main level. The origin is typically referenced to the main rooftop level, or ground level for a structure without access to the antenna level. For example:

Average from 0 feet above to 6 feet above origin  
and  
Average from 20 feet above to 26 feet above origin

The first indicates modeling at the main rooftop (or ground) level averaged over 6 feet. The second indicates modeling at a higher level (possibly a penthouse level) of 20 feet averaged over 6 feet.

**San Mateo County Zoning Hearing Officer Meeting**

Owner/Applicant: \_\_\_\_\_

Attachment: \_\_\_\_\_

File Numbers: \_\_\_\_\_

RF Exposure Simulation For: Jefferson & Sneathy/Martin  
Composite View

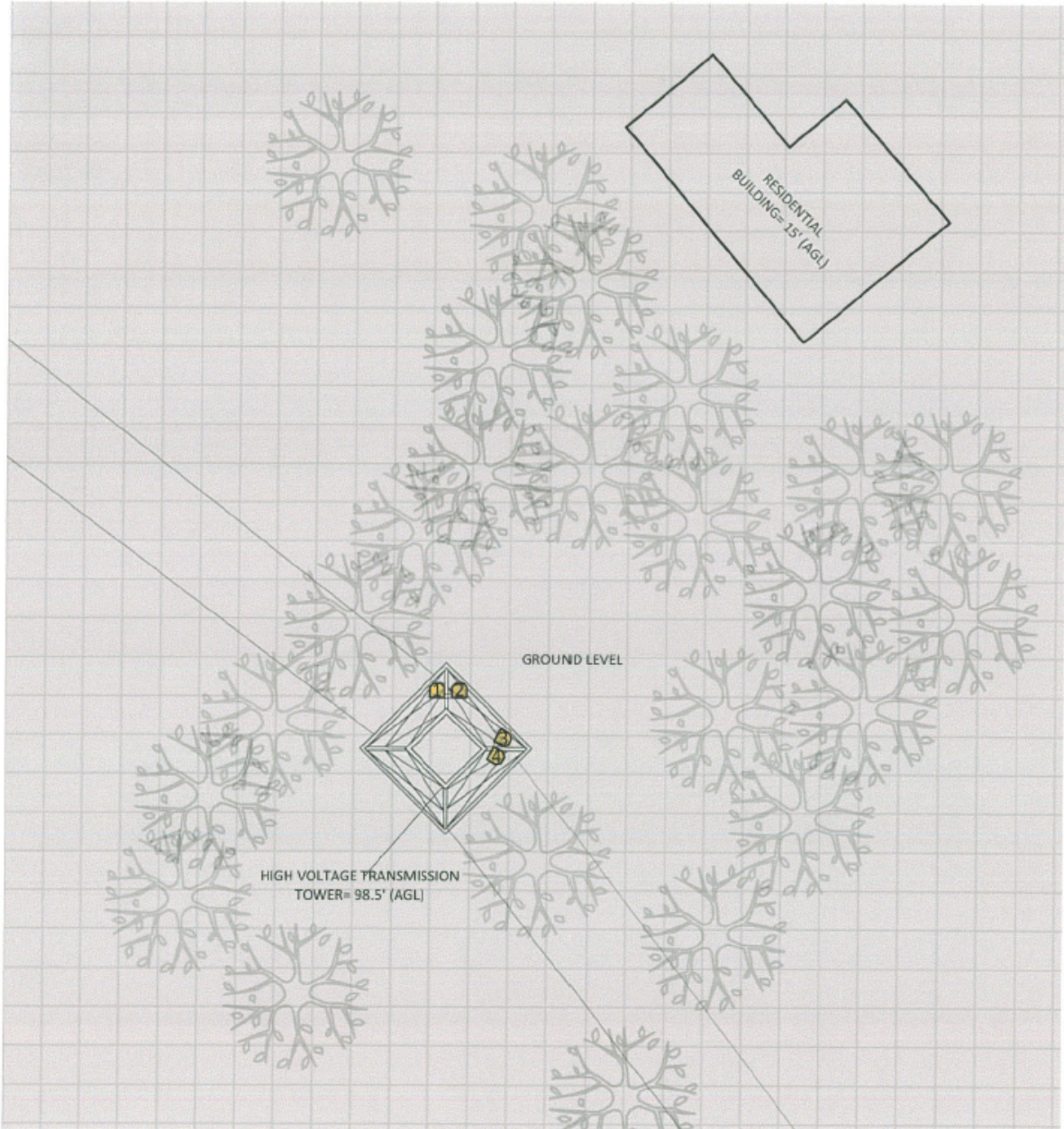

% of FCC Public Exposure Limit  
Spatial average 0' - 6'

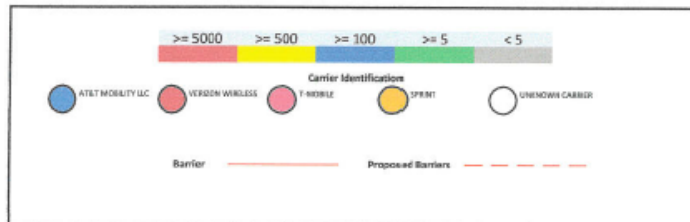
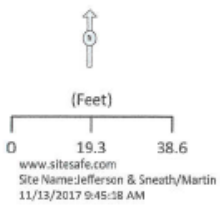

SitesafeTC Version: 1.0.0.0 - 0.0.0.266  
Sitesafe OET-65 Model  
Near Field Boundary: 1.5 \* Aperture  
Reflection Factor: 1  
Spatially Averaged

## San Mateo County Zoning Hearing Officer Meeting

Owner/Applicant: \_\_\_\_\_

Attachment: \_\_\_\_\_

File Numbers: \_\_\_\_\_

RF Exposure Simulation For: Jefferson & Sneath, Martin  
Elevation View

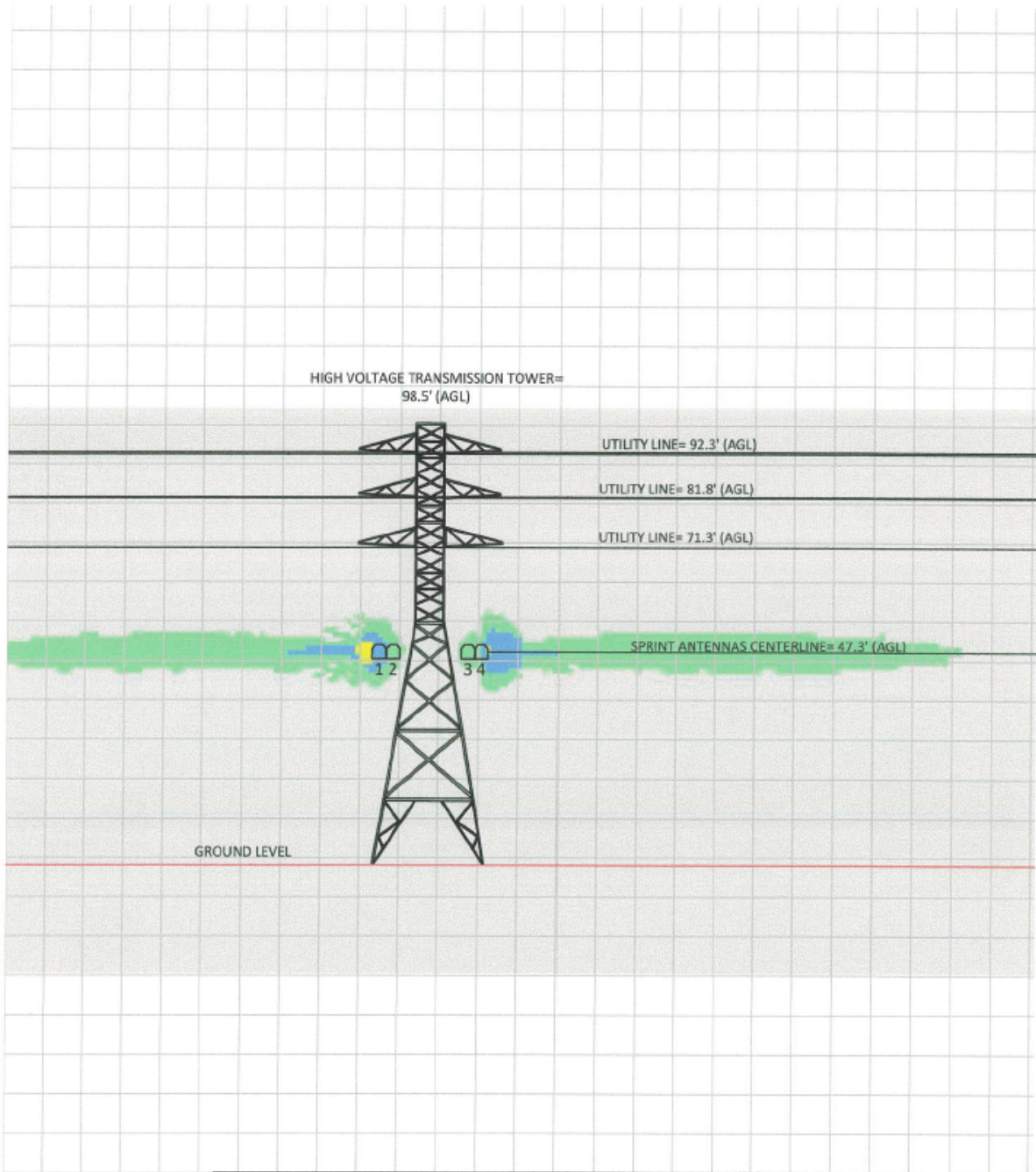

(Feet)  
0 15.3 30.5  
www.sitesafe.com  
Site Name: Jefferson & Sneath/Martin  
11/13/2017 10:09:15 AM

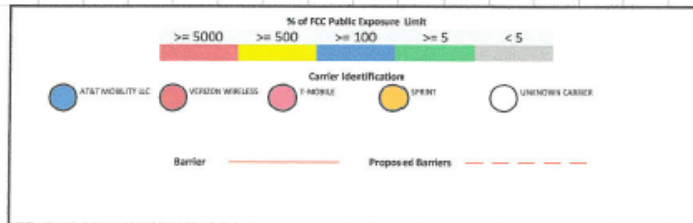

SitesafeTC Version: 1.0.0.0 - 0.0.0.266  
Sitesafe DET-65 Model  
Near Field Boundary: 1.5 \* Aperture  
Reflection Factor: 1  
Single Level (0)

**San Mateo County Zoning Hearing Officer Meeting**

Owner/Applicant:

Attachment:

File Numbers:

## 6 Antenna Inventory

The Antenna Inventory shows all transmitting antennas at the site. This inventory was provided by the customer, and was utilized by Sitesafe to perform theoretical modeling of RF emissions. The inventory coincides with the site diagrams in this report, identifying each antenna's location at FS04XC063 - Jefferson & Sneath/Martin. The antenna information collected includes the following information:

- Licensee or wireless operator name
- Frequency or frequency band
- Transmitter power – Effective Radiated Power ("ERP"), or Equivalent Isotropic Radiated Power ("EIRP") in Watts
- Antenna manufacturer make, model, and gain

For other carriers at this site, the use of "Generic" as an antenna model, or "Unknown" for an operator means the information with regard to carrier, their FCC license and/or antenna information was not available nor could it be secured while on site. Equipment, antenna models and nominal transmit power were used for modeling, based on past experience with radio service providers.

The following antenna inventory, on this and the following page, were provided by the customer and were utilized to create the site model diagrams:

Ant #	Operated By	Antenna Model	Ant Type	Len (ft)	TX Freq (Mhz)	TECH	Az (Deg)	Antenna Gain (dBc)	Horizontal Half Power Beamwidth (Deg)	POWER	POWER TYPE	POWER UNITS	# of Trans	ERP (Watts)	Z (ft) (AGL)	DT	EDT
1	SPRINT (Proposed)	KMW ET-X-TS-70-15-62-18-IR-RD	Panel	4	862	CDMA	0	12.87	70	58	EIRP	dBmW	1	384.1	47.3	0	0
1	SPRINT (Proposed)	KMW ET-X-TS-70-15-62-18-IR-RD	Panel	4	1900	CDMA	0	15.87	62	64	EIRP	dBmW	1	1531.1	47.3	0	0
1	SPRINT (Proposed)	KMW ET-X-TS-70-15-62-18-IR-RD	Panel	4	1900	LTE	0	15.87	62	64	EIRP	dBmW	1	1531.1	47.3	0	0
2	SPRINT (Proposed)	Commscope DT465B-2XR	Panel	6	862	CDMA	0	13.93	64.24	58	EIRP	dBmW	1	384.1	47.3	0	0
2	SPRINT (Proposed)	Commscope DT465B-2XR	Panel	6	2500	LTE	0	15.62	75.67	1600	ERP	Watt	1	1600	47.3	0	0
3	SPRINT (Proposed)	KMW ET-X-TS-70-15-62-18-IR-RD	Panel	4	862	CDMA	120	12.87	70	58	EIRP	dBmW	1	384.1	47.3	0	0
3	SPRINT (Proposed)	KMW ET-X-TS-70-15-62-18-IR-RD	Panel	4	1900	CDMA	120	15.87	62	64	EIRP	dBmW	1	1531.1	47.3	0	0
3	SPRINT (Proposed)	KMW ET-X-TS-70-15-62-18-IR-RD	Panel	4	1900	LTE	120	15.87	62	64	EIRP	dBmW	1	1531.1	47.3	0	0
4	SPRINT (Proposed)	Commscope DT465B-2XR	Panel	6	862	CDMA	120	13.93	64.24	58	EIRP	dBmW	1	384.1	47.3	0	0
4	SPRINT (Proposed)	Commscope DT465B-2XR	Panel	6	2500	LTE	120	15.62	75.67	1600	ERP	Watt	1	1600	47.3	0	0

NOTE: Z indicates relative position of the antenna to the origin location on the site, displayed in the model results diagram. The Z reference indicates antenna height above ground level (AGL). ERP values provided by the client and used in the modeling may be greater than are currently deployed. For other carriers at this site the use of "Generic" as an antenna model or "Unknown" for a wireless operator means the information with regard to carrier, their FCC license and/or antenna information was not available nor could it be secured while on site. Equipment, antenna models and nominal transmit power were used for modeling, based on past experience with radio service providers.

## San Mateo County Zoning Hearing Officer Meeting

Owner/Applicant:

Attachment:

File Numbers:



**7 Engineer Certification**

The professional engineer whose seal appears on the cover of this document hereby certifies and affirms:

That I am registered as a Professional Engineer in the jurisdiction indicated in the professional engineering stamp on the cover of this document; and

That I am an employee of Sitesafe, Inc., in Arlington, Virginia, at which place the staff and I provide RF compliance services to clients in the wireless communications industry; and

That I am thoroughly familiar with the Rules and Regulations of the Federal Communications Commission (FCC) as well as the regulations of the Occupational Safety and Health Administration (OSHA), both in general and specifically as they apply to the FCC Guidelines for Human Exposure to Radio-frequency Radiation; and

That I have thoroughly reviewed this Site Compliance Report and believe it to be true and accurate to the best of my knowledge as assembled by and attested to by Mohamed Frej.

November 13, 2017

**San Mateo County Zoning Hearing Officer Meeting**

Owner/Applicant:

Attachment:

File Numbers:



**Appendix A – Statement of Limiting Conditions**

Sitesafe will not be responsible for matters of a legal nature that affect the site or property.

Due to the complexity of some wireless sites, Sitesafe performed this analysis and created this report utilizing best industry practices and due diligence. Sitesafe cannot be held accountable or responsible for anomalies or discrepancies due to actual site conditions (i.e., mislabeling of antennas or equipment, inaccessible cable runs, inaccessible antennas or equipment, etc.) or information or data supplied by Sprint, the site manager, or their affiliates, subcontractors or assigns.

Sitesafe has provided computer generated model(s) in this Site Compliance Report to show approximate dimensions of the site, and the model is included to assist the reader of the compliance report to visualize the site area, and to provide supporting documentation for Sitesafe's recommendations.

Sitesafe may note in the Site Compliance Report any adverse physical conditions, such as needed repairs, observed during the survey of the subject property or that Sitesafe became aware of during the normal research involved in performing this survey. Sitesafe will not be responsible for any such conditions that do exist or for any engineering or testing that might be required to discover whether such conditions exist. Because Sitesafe is not an expert in the field of mechanical engineering or building maintenance, the Site Compliance Report must not be considered a structural or physical engineering report.

Sitesafe obtained information used in this Site Compliance Report from sources that Sitesafe considers reliable and believes them to be true and correct. Sitesafe does not assume any responsibility for the accuracy of such items that were furnished by other parties. When conflicts in information occur between data provided by a second party and physical data collected by Sitesafe, the physical data will be used.

**San Mateo County Zoning Hearing Officer Meeting**

Owner/Applicant:

Attachment:

File Numbers:



## Appendix B – Assumptions and Definitions

### General Model Assumptions

In this site compliance report, it is assumed that all antennas are operating at **full power at all times**. Software modeling was performed for all transmitting antennas located on the site. Sitesafe has further assumed a 100% duty cycle and maximum radiated power.

The site has been modeled with these assumptions to show the maximum RF energy density. Sitesafe believes this to be a *worst-case* analysis, based on best available data. Areas modeled to predict emissions greater than 100% of the applicable MPE level may not actually occur, but are shown as a *worst-case* prediction that could be realized real time. Sitesafe believes these areas to be safe for entry by occupationally trained personnel utilizing appropriate personal protective equipment (in most cases, a personal monitor).

Thus, at any time, if power density measurements were made, we believe the real-time measurements would indicate levels below those depicted in the RF emission diagram(s) in this report. By modeling in this way, Sitesafe has conservatively shown exclusion areas – areas that should not be entered without the use of a personal monitor, carriers reducing power, or performing real-time measurements to indicate real-time exposure levels.

### Use of Generic Antennas

For the purposes of this report, the use of "Generic" as an antenna model, or "Unknown" for an operator means the information about a carrier, their FCC license and/or antenna information was not provided and could not be obtained while on site. In the event of unknown information, Sitesafe will use our industry specific knowledge of equipment, antenna models, and transmit power to model the site. If more specific information can be obtained for the unknown measurement criteria, Sitesafe recommends remodeling of the site utilizing the more complete and accurate data. Information about similar facilities is used when the service is identified and associated with a particular antenna. If no information is available regarding the transmitting service associated with an unidentified antenna, using the antenna manufacturer's published data regarding the antenna's physical characteristics makes more conservative assumptions.

Where the frequency is unknown, Sitesafe uses the closest frequency in the antenna's range that corresponds to the highest Maximum Permissible Exposure (MPE), resulting in a conservative analysis.

## San Mateo County Zoning Hearing Officer Meeting

Owner/Applicant:

Attachment:

File Numbers:





**Definitions**

**5% Rule** – The rules adopted by the FCC specify that, in general, at multiple transmitter sites actions necessary to bring the area into compliance with the guidelines are the shared responsibility of all licensees whose transmitters produce field strengths or power density levels at the area in question in excess of 5% of the exposure limits. In other words, any wireless operator that contributes 5% or greater of the MPE limit in an area that is identified to be greater than 100% of the MPE limit is responsible taking corrective actions to bring the site into compliance.

**Compliance** – The determination of whether a site is safe or not with regards to Human Exposure to Radio Frequency Radiation from transmitting antennas.

**Decibel (dB)** – A unit for measuring power or strength of a signal.

**Duty Cycle** – The percent of pulse duration to the pulse period of a periodic pulse train. Also, may be a measure of the temporal transmission characteristic of an intermittently transmitting RF source such as a paging antenna by dividing average transmission duration by the average period for transmission. A duty cycle of 100% corresponds to continuous operation.

**Effective (or Equivalent) Isotropic Radiated Power (EIRP)** – The product of the power supplied to the antenna and the antenna gain in a given direction relative to an isotropic antenna.

**Effective Radiated Power (ERP)** – In a given direction, the relative gain of a transmitting antenna with respect to the maximum directivity of a half wave dipole multiplied by the net power accepted by the antenna from the connecting transmitter.

**Gain (of an antenna)** – The ratio of the maximum intensity in a given direction to the maximum radiation in the same direction from an isotropic radiator. Gain is a measure of the relative efficiency of a directional antennas as compared to an omni directional antenna.

**General Population/Uncontrolled Environment** – Defined by the FCC, as an area where RFR exposure may occur to persons who are **unaware** of the potential for exposure and who have no control of their exposure. General Population is also referenced as General Public.

**Generic Antenna** – For the purposes of this report, the use of "Generic" as an antenna model means the antenna information was not provided and could not be obtained while on site. In the event of unknown information, Sitesafe will use our industry specific knowledge of antenna models to select a worst case scenario antenna to model the site.

**Isotropic Antenna** – An antenna that is completely non-directional. In other words, an antenna that radiates energy equally in all directions.

**Maximum Measurement** – This measurement represents the single largest measurement recorded when performing a spatial average measurement.

**San Mateo County Zoning Hearing Officer Meeting**

Owner/Applicant:

Attachment:

File Numbers:



**Maximum Permissible Exposure (MPE)** – The rms and peak electric and magnetic field strength, their squares, or the plane-wave equivalent power densities associated with these fields to which a person may be exposed without harmful effect and with acceptable safety factor.

**Occupational/Controlled Environment** – Defined by the FCC, as an area where Radio Frequency Radiation (RFR) exposure may occur to persons who are **aware** of the potential for exposure as a condition of employment or specific activity and can exercise control over their exposure.

**OET Bulletin 65** – Technical guideline developed by the FCC's Office of Engineering and Technology to determine the impact of Radio Frequency radiation on Humans. The guideline was published in August 1997.

**OSHA (Occupational Safety and Health Administration)** – Under the Occupational Safety and Health Act of 1970, employers are responsible for providing a safe and healthy workplace for their employees. OSHA's role is to promote the safety and health of America's working men and women by setting and enforcing standards; providing training, outreach and education; establishing partnerships; and encouraging continual process improvement in workplace safety and health. For more information, visit [www.osha.gov](http://www.osha.gov).

**Radio Frequency Radiation** – Electromagnetic waves that are propagated from antennas through space.

**Spatial Average Measurement** – A technique used to average a minimum of ten (10) measurements taken in a ten (10) second interval from zero (0) to six (6) feet. This measurement is intended to model the average energy an average sized human body will absorb while present in an electromagnetic field of energy.

**Transmitter Power Output (TPO)** – The radio frequency output power of a transmitter's final radio frequency stage as measured at the output terminal while connected to a load.

## San Mateo County Zoning Hearing Officer Meeting

Owner/Applicant: \_\_\_\_\_

Attachment: \_\_\_\_\_

File Numbers: \_\_\_\_\_



## Appendix C – Rules & Regulations

### Explanation of Applicable Rules and Regulations

The FCC has set forth guidelines in OET Bulletin 65 for human exposure to radio frequency electromagnetic fields. Specific regulations regarding this topic are listed in Part 1, Subpart I, of Title 47 in the Code of Federal Regulations. Currently, there are two different levels of MPE - General Public MPE and Occupational MPE. An individual classified as Occupational can be defined as an individual who has received appropriate RF training and meets the conditions outlined below. General Public is defined as anyone who does not meet the conditions of being Occupational. FCC and OSHA Rules and Regulations define compliance in terms of total exposure to total RF energy, regardless of location of or proximity to the sources of energy.

It is the responsibility of all licensees to ensure these guidelines are maintained at all times. It is the ongoing responsibility of all licensees composing the site to maintain ongoing compliance with FCC rules and regulations. Individual licensees that contribute less than 5% MPE to any total area out of compliance are not responsible for corrective actions.

OSHA has adopted and enforces the FCC's exposure guidelines. A building owner or site manager can use this report as part of an overall RF Health and Safety Policy. It is important for building owners/site managers to identify areas in excess of the General Population MPE and ensure that only persons qualified as Occupational are granted access to those areas.

### Occupational Environment Explained

The FCC definition of Occupational exposure limits apply to persons who:

- are exposed to RF energy as a consequence of their employment;
- have been made aware of the possibility of exposure; and
- can exercise control over their exposure.

OSHA guidelines go further to state that persons must complete RF Safety Awareness training and must be trained in the use of appropriate personal protective equipment.

In order to consider this site an Occupational Environment, the site must be controlled to prevent access by any individuals classified as the General Public. Compliance is also maintained when any non-occupational individuals (the General Public) are prevented from accessing areas indicated as Red or Yellow in the attached RF Emissions diagram. In addition, a person must be aware of the RF environment into which they are entering. This can be accomplished by an RF Safety Awareness class, and by appropriate written documentation such as this Site Compliance Report.

All Sprint employees who require access to this site must complete RF Safety Awareness training and must be trained in the use of appropriate personal protective equipment.

## San Mateo County Zoning Hearing Officer Meeting

Owner/Applicant:

Attachment:

File Numbers:

## Appendix D – General Safety Recommendations

The following are *general recommendations* appropriate for any site with accessible areas in excess of 100% General Public MPE. These recommendations are not specific to this site. These are safety recommendations appropriate for typical site management, building management, and other tenant operations.

1. All individuals needing access to the main site (or the area indicated to be in excess of General Public MPE) should wear a personal RF Exposure monitor, successfully complete proper RF Safety Awareness training, and have and be trained in the use of appropriate personal protective equipment.
2. All individuals needing access to the main site should be instructed to read and obey all posted placards and signs.
3. The site should be routinely inspected and this or similar report updated with the addition of any antennas or upon any changes to the RF environment including:
  - adding new antennas that may have been located on the site
  - removing of any existing antennas
  - changes in the radiating power or number of RF emitters
4. Post the appropriate **NOTICE**, **CAUTION**, or **WARNING** sign at the main site access point(s) and other locations as required. Note: Please refer to RF Exposure Diagrams in Appendix B, to inform everyone who has access to this site that beyond posted signs there may be levels in excess of the limits prescribed by the FCC. The signs below are examples of signs meeting FCC guidelines.



5. Ensure that the site door remains locked (or appropriately controlled) to deny access to the general public if deemed as policy by the building/site owner.
6. For a General Public environment the four color levels identified in this analysis can be interpreted in the following manner:
  - Gray represents area at below 5% of the General Public MPE limits or below. This level is safe for a worker to be in at any time.
  - Green represents areas predicted to be between 5% and 100% of the General Public MPE limits. This level is safe for a worker to be in at any time.

## San Mateo County Zoning Hearing Officer Meeting

Owner/Applicant: \_\_\_\_\_

Attachment: \_\_\_\_\_

File Numbers: \_\_\_\_\_



- Blue represents areas predicted to be between 100% and 500% of the General Public MPE limits. This level is safe for a worker to be in at any time.
- Yellow represents areas predicted to be between 500% and 5000% of the General Public MPE limits. This level is safe for a worker to be in.
- Red areas indicated predicted levels greater than 5000% of the General Public MPE limits. This level is not safe for the General Public to be in.

7. For an Occupational environment the five color levels identified in this analysis can be interpreted in the following manner:

- Areas indicated as Gray are at 5% of the Occupational MPE limits or below. This level is safe for a worker to be in at any time.
- Green represents areas predicted to be between 5% and 20% of the Occupational MPE limits. This level is safe for a worker to be in at any time.
- Blue represents areas predicted to be between 20% and 100% of the Occupational MPE limits. This level is safe for a worker to be in at any time.
- Yellow represents areas predicted to be between 100% and 500% of the Occupational MPE limits. Only individuals that have been properly trained in RF Health and Safety should be allowed to work in this area. This is not an area that is suitable for the General Public to be in.
- Red areas indicated predicted levels greater than 500% of the Occupational MPE limits. This level is not safe for the Occupational worker to be in for prolonged periods of time. Special procedures must be adhered to such as lock out tag out procedures to minimize the workers exposure to EME.

8. Use of a Personal Protective Monitor: When working around antennas, Sitesafe strongly recommends the use of a Personal Protective Monitor (PPM). Wearing a PPM will properly forewarn the individual prior to entering an RF exposure area.

Keep a copy of this report available for all persons who must access the site. They should read this report and be aware of the potential hazards with regards to RF and MPE limits.

**Additional Information**

Additional RF information is available by visiting both [www.Sitesafe.com](http://www.Sitesafe.com) and [www.fcc.gov/oet/rfsafety](http://www.fcc.gov/oet/rfsafety). OSHA has additional information available at: <http://www.osha-slc.gov/SLTC/radiofrequencyradiation>.

**San Mateo County Zoning Hearing Officer Meeting**

Owner/Applicant:

Attachment:

File Numbers: